

# **MINI MAG**

# **2800**

## **MODEL**

# **INSTALLATION**

# **INSTRUCTIONS**

**Boat Lifts Unlimited**  
**Odenton, Maryland**  
**410-674-3100**

**Prior to installation:**

- a). To insure that the lift will operate properly, adequate electricity should be available. Electricity will also be needed to install the lift.
- b). Insure that the pilings are at least 12" high above the deck of the pier.
- c). The lift pilings should be driven in the ground to the dock or seawall . Otherwise the weight of the boat will pull the piles over.
- d). If existing piles are to be used, insure they are not cracked or show any signs of decay.
- e). obtain any locally required permits.

**DO NOT USE ANY POWER TOOLS WHILE STANDING IN THE WATER. IF ELECTRICITY MUST BE USED NEAR THE WATER, INSURE THAT THE CIRCUIT IS PROTECTED BY A GROUND FAULT INTERRUPTER.**

MAIN DRAWINGS-MANUAL 2 (LIFT #2800) DATE 06-23-00

1. 2800 ASSEMBLY DRAWING, PART NAMES (PILING MOUNT)
2. ASSEMBLY DRAWING (SEAWALL MOUNT-OPTIONAL)
3. INSTALLATION PART NUMBERS
4. EXPLODED VIEW
5. KEY TO DETAIL DRAWINGS
6. CABLE CONNECTION ASSEMBLY DETAIL AND CABLE ATTACHMENT
7. TRACK INSTALLATION DETAIL (PILING MOUNT)
8. TRACK INSTALLATION DETAIL (SEAWALL MOUNT-OPTIONAL)
9. CROSS ANGLE BRACE INSTALLATION
10. CHOCK RAILS ASSEMBLY DETAIL
11. INSTRUCTIONS FOR WEIGHT DISTRIBUTION

LIST

1. PARTS LIST (SHEETS 2)

## INSTALLATION INSTRUCTIONS MINI MAG 2800 LB. LIFT

- 1) Determine which pilings are to be used to mount the Mini Mag Lift to. Timber piles should be 8" in diameter or greater. Square piles should be 6" x 6" or greater. Both pilings must be tied back to the dock or sea wall. There should be 8' - 12' maximum between piles. Ideal distance is 10'.
- 2) Mount the tracks as per figure #05. The top of the track should be 2 feet above the deck or seawall cap. It is not necessary for the track to reach the bottom. It should reach to 3' below low water. Be sure to install the 3" dock washer behind the head of the 5/8" carriage mounting bolt and the 5/8" x 1 1/2" stop bolt at the bottom of the track. The track should have a slight backward pitch. It may be necessary to install a wooden shim between the channel spacer and the track to compensate for a out of plumb piling. Figure #05.
- 3) Lubricate the stainless steel axles with a marine grease and install the poly rollers. Apply some grease to the inside walls of the track to lube the poly rollers. Clamp a set of vice grips on the lip of the track 3' down from the top of the track. Install the arms in the track and lower the arm until it rests on the vice grips.
- 4) Install the AMS 1500 with the electric motor mounts to the top of the track. Install the cable in accordance with figure #08 and the blue nylon sheave as per figure #07. Plug in the power cord. Firmly grasp the cable using leather gloves and turn the switch to the up position. Neatly wind the cable onto the drum.
- 5) Install the diagonal angle as per figure #09. Install the PVC guide bases onto the arm as close to the track as possible. Determine the width of the vessel being lifted. If the vessel is 8' wide, measure out 4' from the guide. This will be your center mark for installing the timber runners. Install the timber runners in accordance with figure #10. Initially set the runners at about 36" apart for a VEE bottom boat. That would be a 18" on either side of the center mark.

\*\*\*\*\*

### IMPORTANT

Apply a good heavy grease to the winch gears. Use the two zirk fittings located on either side of the worm gear. If the gears are not lubricated after installation the lift will bind and wear the gears producing a fine powder and a scraping noise.

\*\*\*\*\*

## INSTALLATION INSTRUCTIONS MINI MAG 2800 LB. LIFT CON'T.

- 6) Check all nuts and bolts to be sure they are tight before fitting the boat onto the lift. Lower the lift to a depth deep enough to move the boat over the lift. Place the boat more forward so the transom extends 1' - 2' past the stern lifting arm. Raise the boat and adjust runners if required to securely hold the boat. Figure #11.

### \*\*\*\*\*IMPORTANT\*\*\*\*\*

DO NOT HARDWIRE THIS LIFT OR LEAVE IT PLUGGED IN WHILE NOT IN USE TO ELECTRICAL CIRCUIT. IF THE GROUND WIRE IS ALLOWED TO REMAIN CONNECTED TO THE CIRCUIT WHILE THE LIFT IS NOT IN USE, ELECTROLYSIS WILL OCCUR. THIS WILL CORRODE THE TRACK AT A GREATLY ACCELERATED RATE.

**2800 lb. MINI MAG LOAD SHEET  
PARTS LIST**

NO.	ITEMS	QTY
1	6' CRADLE ARM (SINGLE I-BEAM)	2
2	TRACKS 8'/10'/12'	2
4	AMS 1500 WINCH WITH COVER (8" PULLEY & 4L280 BELT)	2
5	ELECTRIC MOTOR MOUNTS	4
6	3" NYLON SHEAVE	2
7	1/4" CABLE 14'/18'/22'	2
8	POLY ROLLERS	8
9	2 1/2" x 2 1/2" x 12' CROSS ANGLE	1
10	8' PVC GUIDE POLE SECTION	2
11	PVC GUIDE POLE CAPS	2
12	GUIDE POLE STANCHIONS (BASE)	2
13	2" x 8" x 12' TIMBER RUNNERS-CARPETED	2
14	BUNK BRACKETS-4 EA L AND R 12"	8
15	5" WIDE CARPET x 14' LONG (WHOLESALE ONLY)	2
16	5/8" x 1 1/2" GAL HEX BOLTS (STOP BOLT)	2
16a	5/8" GAL NUTS	6
18	3/8" x 1" CARRIAGE BOLTS	8
18a	3/8" GAL NUTS	8
19	1/2" x 2 1/2" STAINLESS HEX BOLTS	2
19a	1/2" STAINLESS LOCK NUTS	2
20	3/8" x 1" GAL HEX BOLTS	2
20a	3/8" GAL NUTS	10
21	3/8" x 2 1/2" GAL CARRIAGE BOLTS	8
21a	3/8" GAL NUTS	8
22	1/2" x 4 1/2" GAL HEX BOLTS	8
22a	1/2" GAL NUTS	8
23	3/8" x 5" GAL HEX BOLTS	2
23a	3/8" GAL NUTS	2
24	1 1/2" x 1/2" STAINLESS STEEL CARRIAGE BOLT	2
24a	1/2" GAL WASHER	6
24b	1/2" GAL LOCK WASHER	2
24c	1/2" GAL NUT	2
25	3/16" CABLE CLAMP	2
26	AMS POLY COVER	2
27	BACKING PLATE	2

**2800 lb. MINI MAG LOAD SHEET  
PARTS LIST**

**MOUNTING**

<b>NO.</b>	<b>PILE MOUNTED</b>	<b>QTY</b>
3	BACKING CHANNELS (SPACER)	4
17	5/8" x 14" CARRIAGE BOLTS	4
17a	5/8" DOCK WASHER WITH SQUARE ID 3" OD	4
17b	5/8" WASHER	4
17c	3/8" GAL NUTS	4
<b>OPTIONAL</b>		
28	SEAWALL MOUNT	1

GENERAL NOTE:

⚠ IMPORTANT—PILINGS MUST BE SECURELY ANCHORED TO A SEAWALL OR INTEGRATED INTO A DOCK.

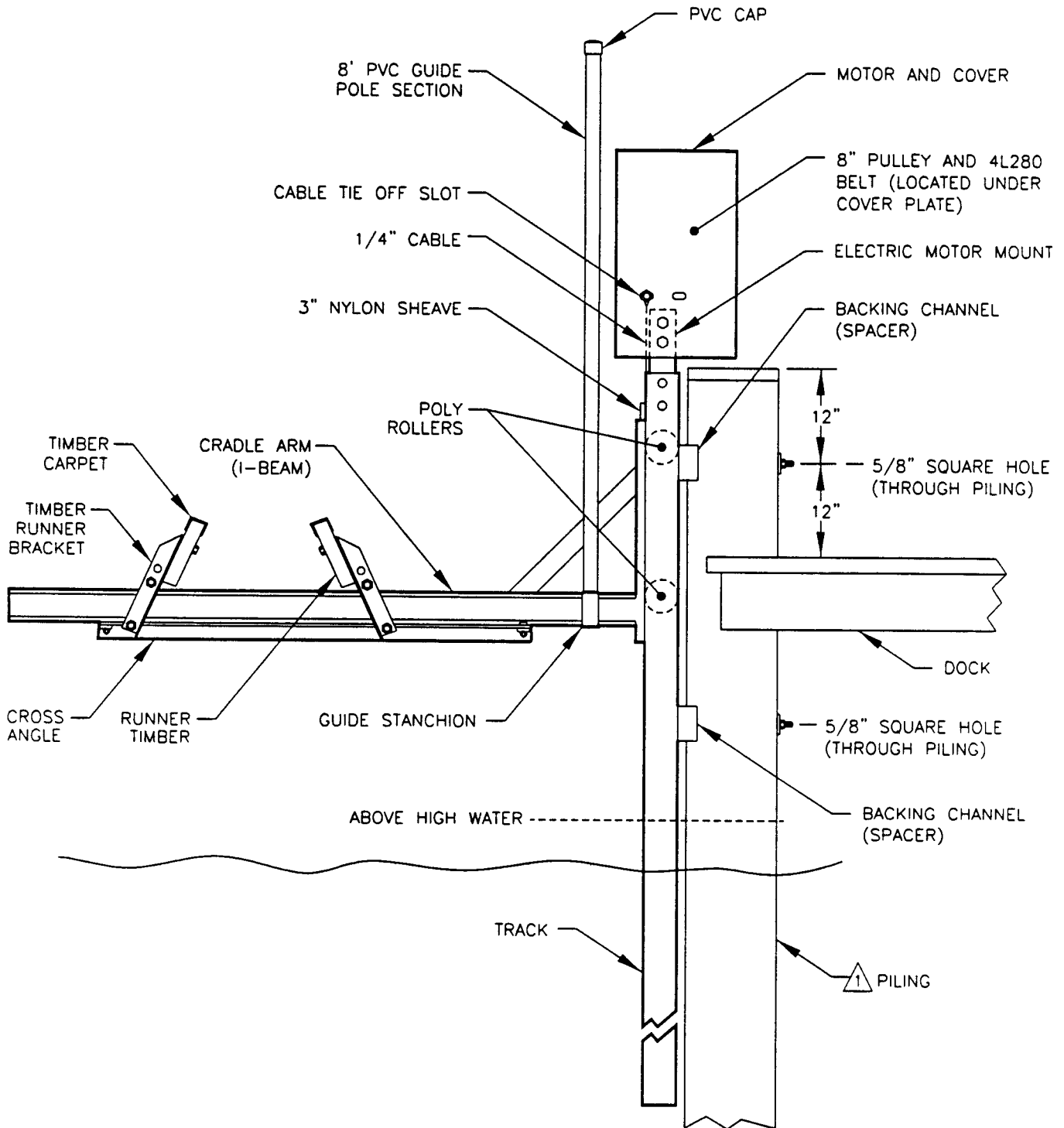

Project: 2800 Assembly Drawing Part Names (Piling Mount)		
No.: 001	Revision Date:	
Scale: None	Date: 06-12-00	Sheet: 1 of 1

GENERAL NOTE:

⚠ IMPORTANT—PILINGS MUST BE SECURELY ANCHORED TO A SEAWALL OR INTEGRATED INTO A DOCK.

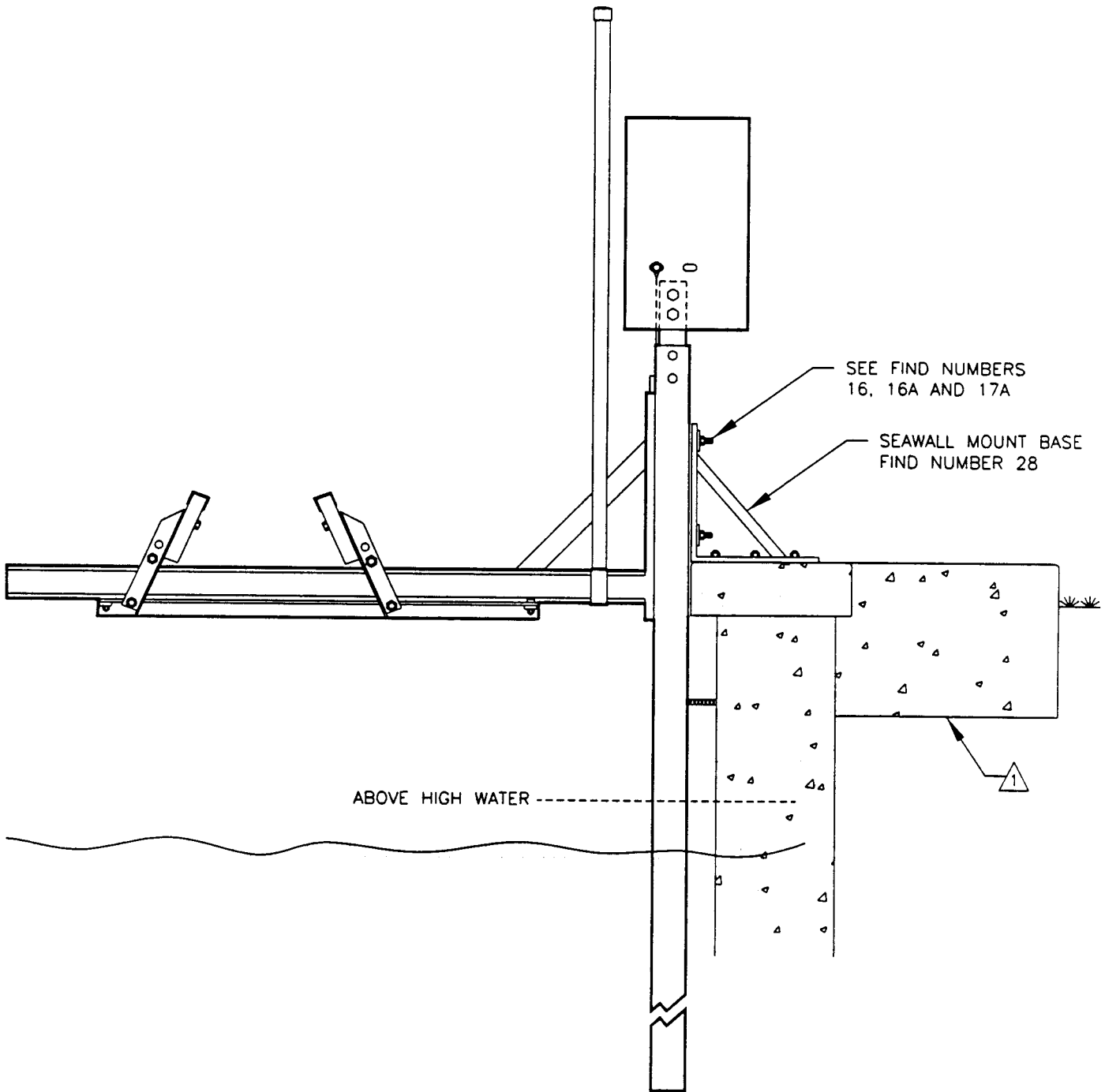

Project: Assembly Drawing (Seawall Mount-Optional)		
No.: 002	Revision Date:	
Scale: None	Date: 07-28-00	Sheet: 1 of 1



GENERAL NOTE:

1. FOR LIST OF MATERIALS RELATED TO PART NUMBERS, SEE PARTS LIST.

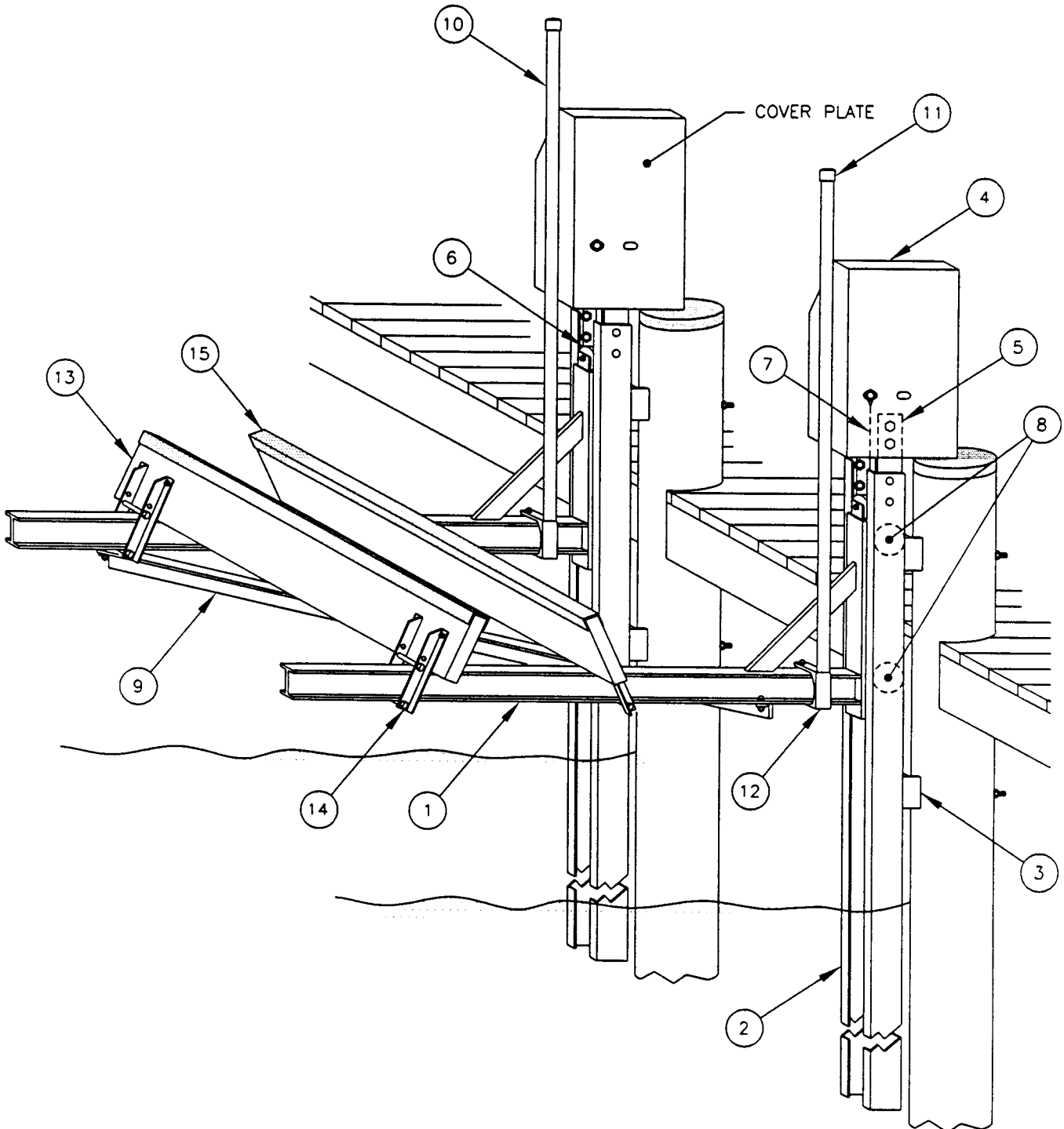

Project: 2800 Installation Part Numbers		
No.: 003	Revision Date:	
Scale: None	Date: 06-13-00	Sheet: 1 of 1

GENERAL NOTE:

- 1. FOR A DETAIL DRAWING OF VIEW CALLED OUT, GO TO SPECIFIED DRAWING.

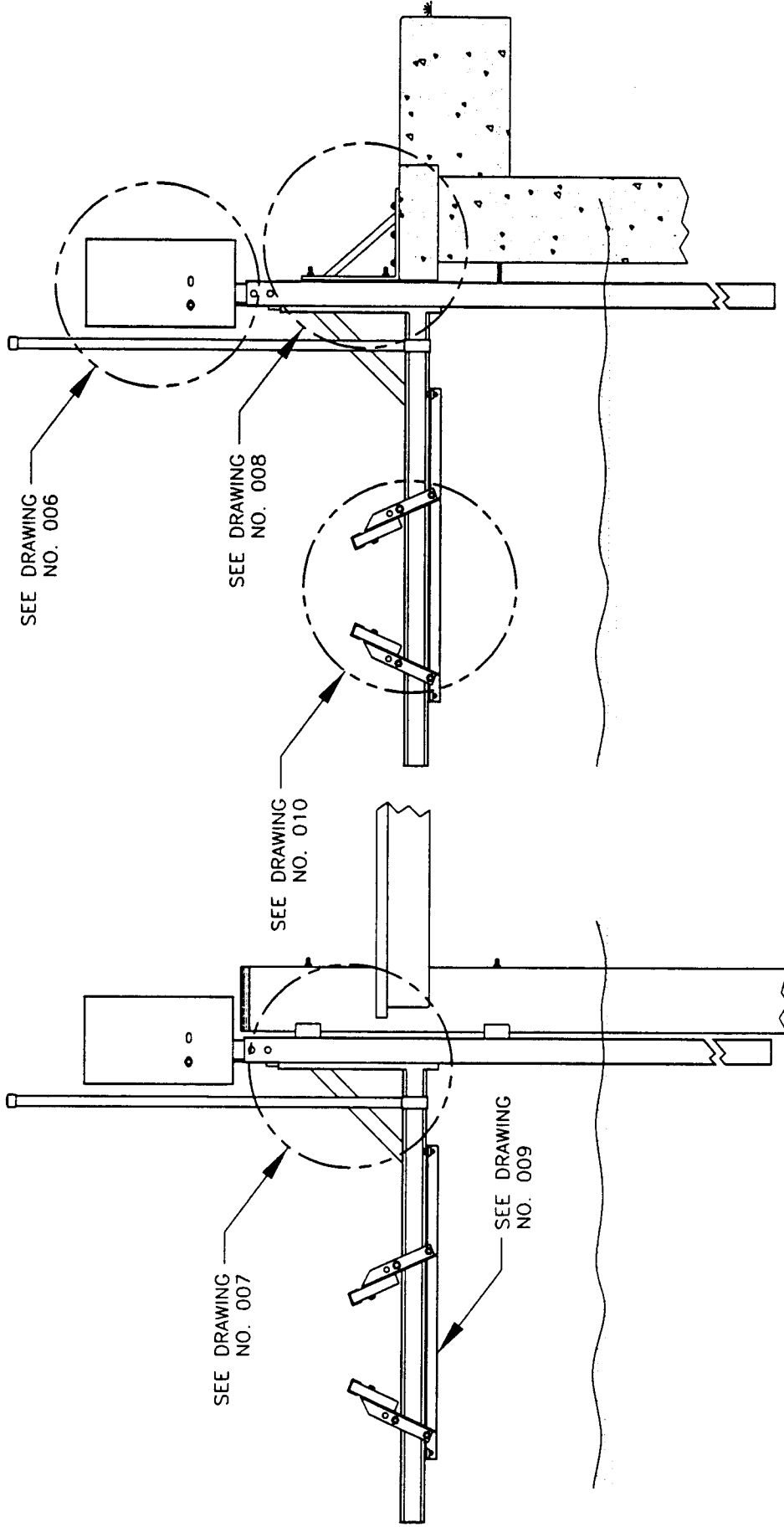

Project: Key To Detail  
Drawings

No: 004      Revision Date:

Scale: None      Date: 07-20-00      Sheet: 1 of 1

GENERAL NOTES:

- ① IMPORTANT—PILINGS MUST BE SECURELY ANCHORED TO A SEAWALL OR INTEGRATED INTO A DOCK.
- ② IMPORTANT—IT IS NOT NECESSARY FOR THE TRACK TO EXTEND TO THE WATER BOTTOM IN DEEP WATER.
- ③ 8'/10'/12' TRACK LENGTH

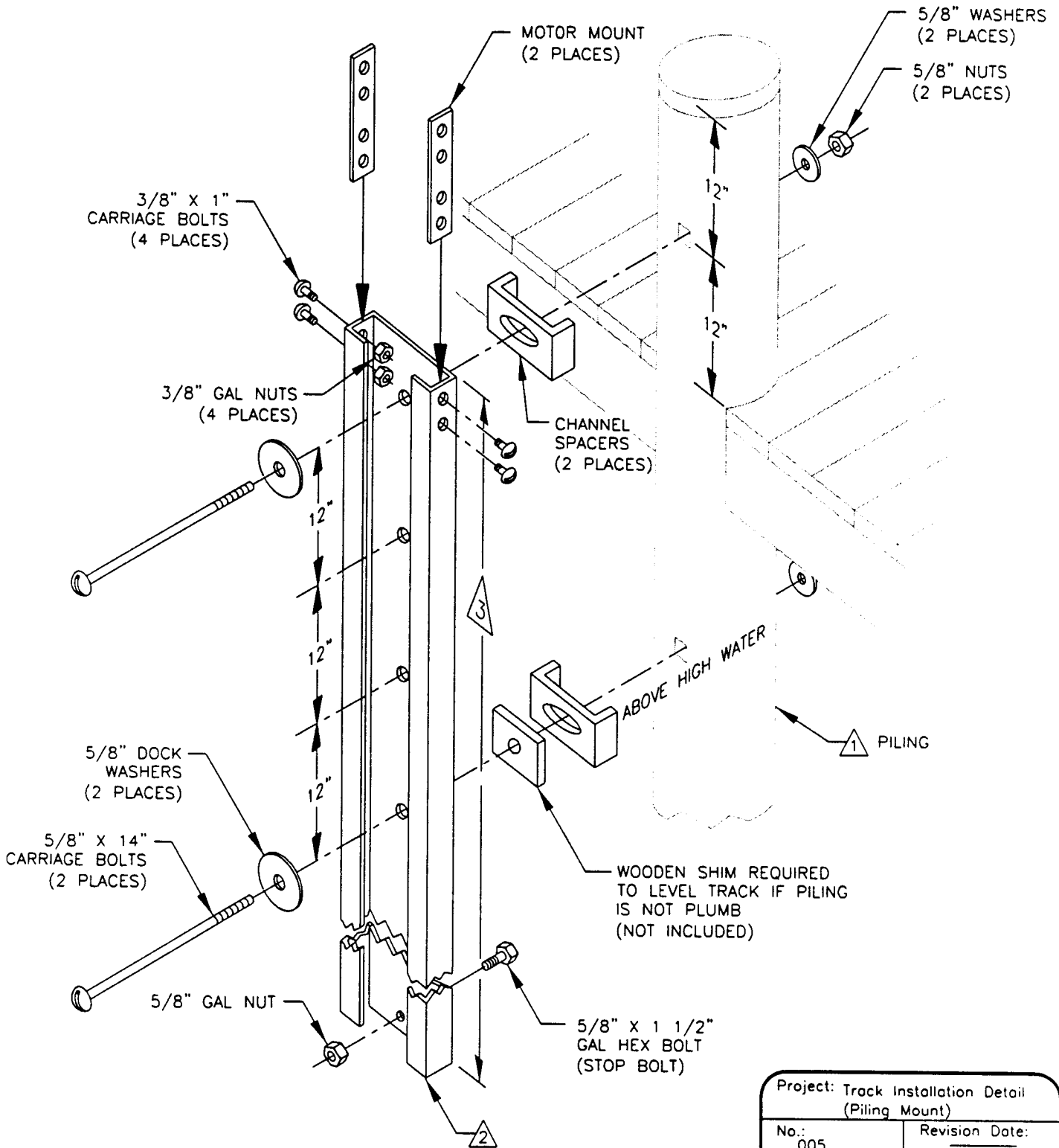

Project: Track Installation Detail (Piling Mount)		
No.: 005	Revision Date:	
Scale: None	Date: 07-19-00	Sheet: 1 of 1

GENERAL NOTES:

- ⚠ IMPORTANT—IT IS NOT NECESSARY FOR THE TRACK TO EXTEND TO THE WATER BOTTOM IN DEEP WATER.
- ② 8'/10'/12' TRACK LENGTH

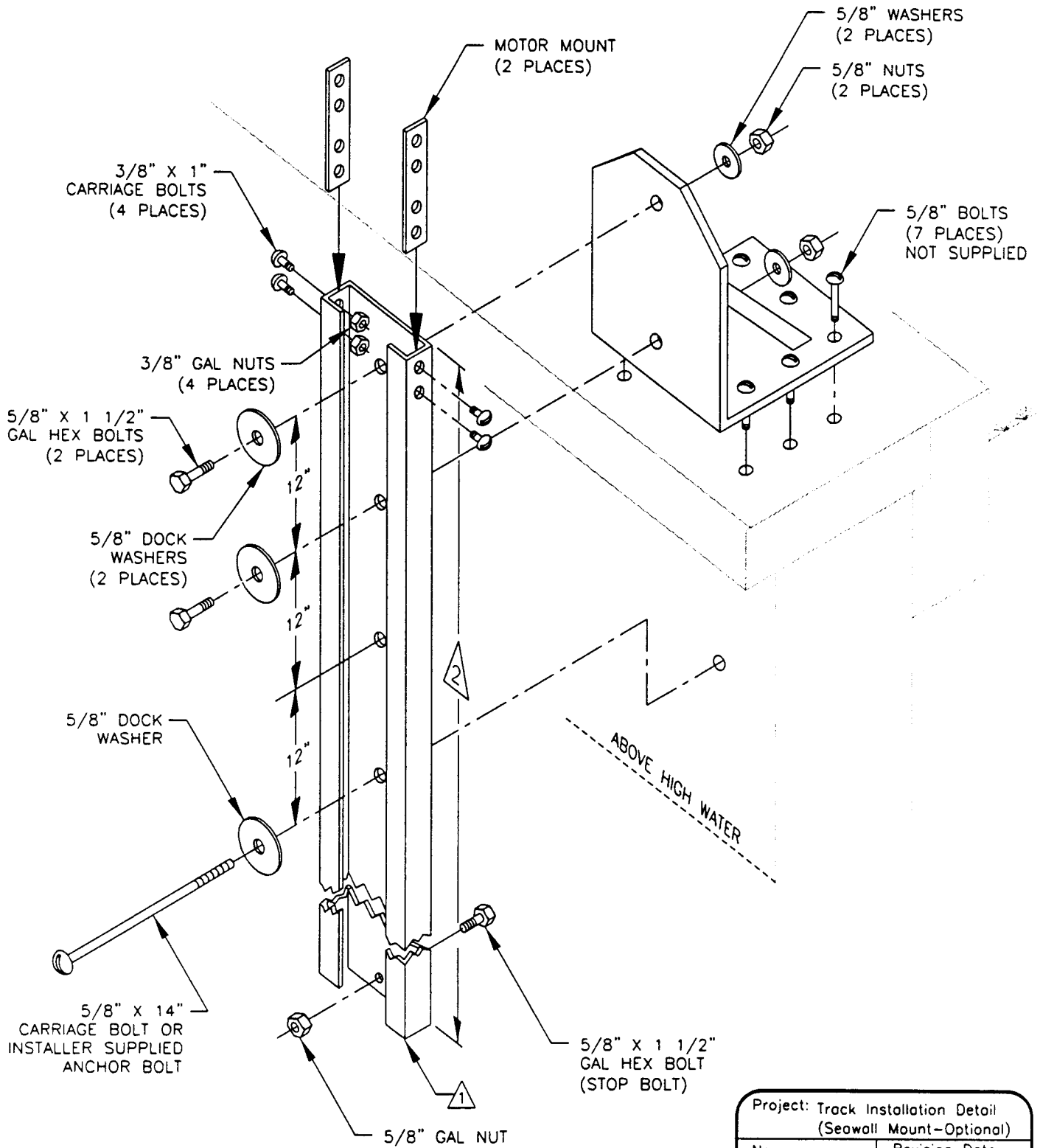

Project: Track Installation Detail (Seawall Mount—Optional)		
No.: 006	Revision Date:	
Scale: None	Date: 08-03-00	Sheet: 1 of 1

GENERAL NOTE:

1. FOR LIST OF MATERIALS RELATED TO PART NUMBERS, SEE PARTS LIST.

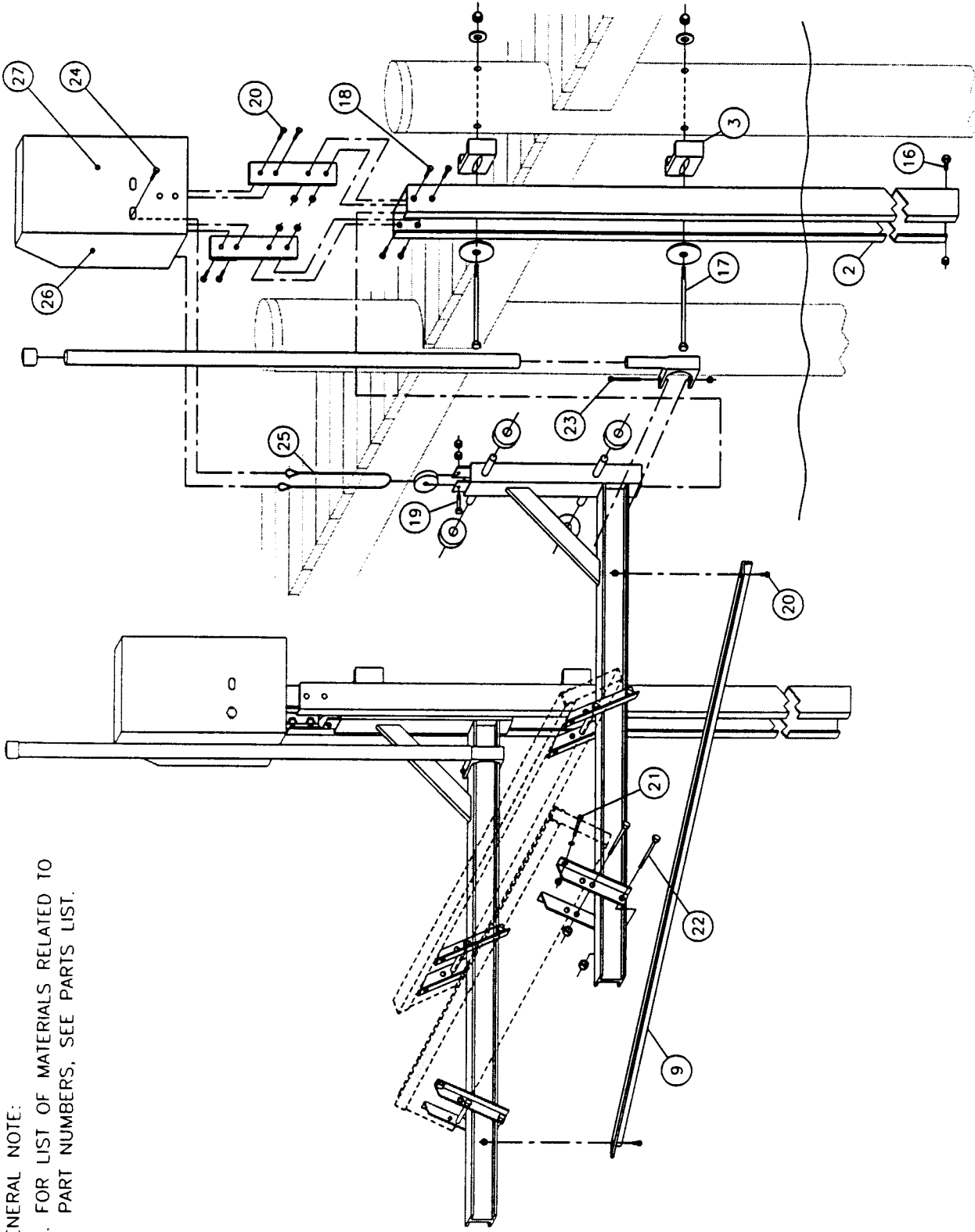

Project: Exploded View	
No.: 007	Revision Date:
Scale: None	Date: 07-16-00
Sheet: 1 of 1	

**BOAT LIFTS UNLIMITED, INC.**

**GENERAL NOTES:**

1. FOR LIST OF MATERIALS RELATED TO PART NUMBERS, SEE PARTS LIST.

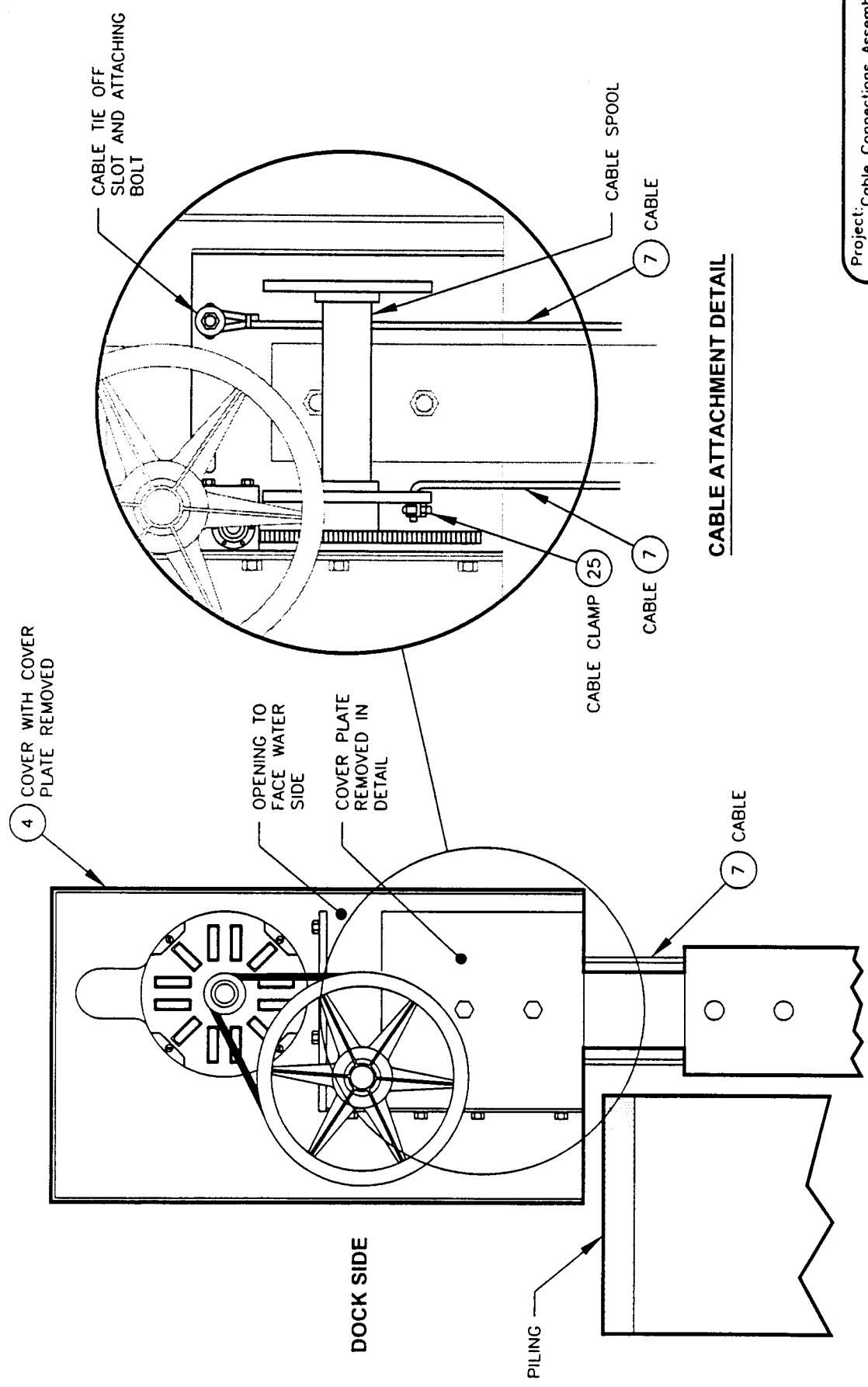

**CABLE ATTACHMENT DETAIL**

Project: Cable Connections Assembly Detail and Cable Attachment	
No.: 008	Revision Date:
Scale: None	Date: 07-25-00
	Sheet: 1 of 1

**GENERAL NOTES:**

1. ATTACH TIMBER RUNNER BRACKETS AND CROSS ANGLE BRACE TO CRADLE ARMS.
2. FOR LIST OF MATERIALS RELATED TO PART NUMBERS, SEE PARTS LIST.

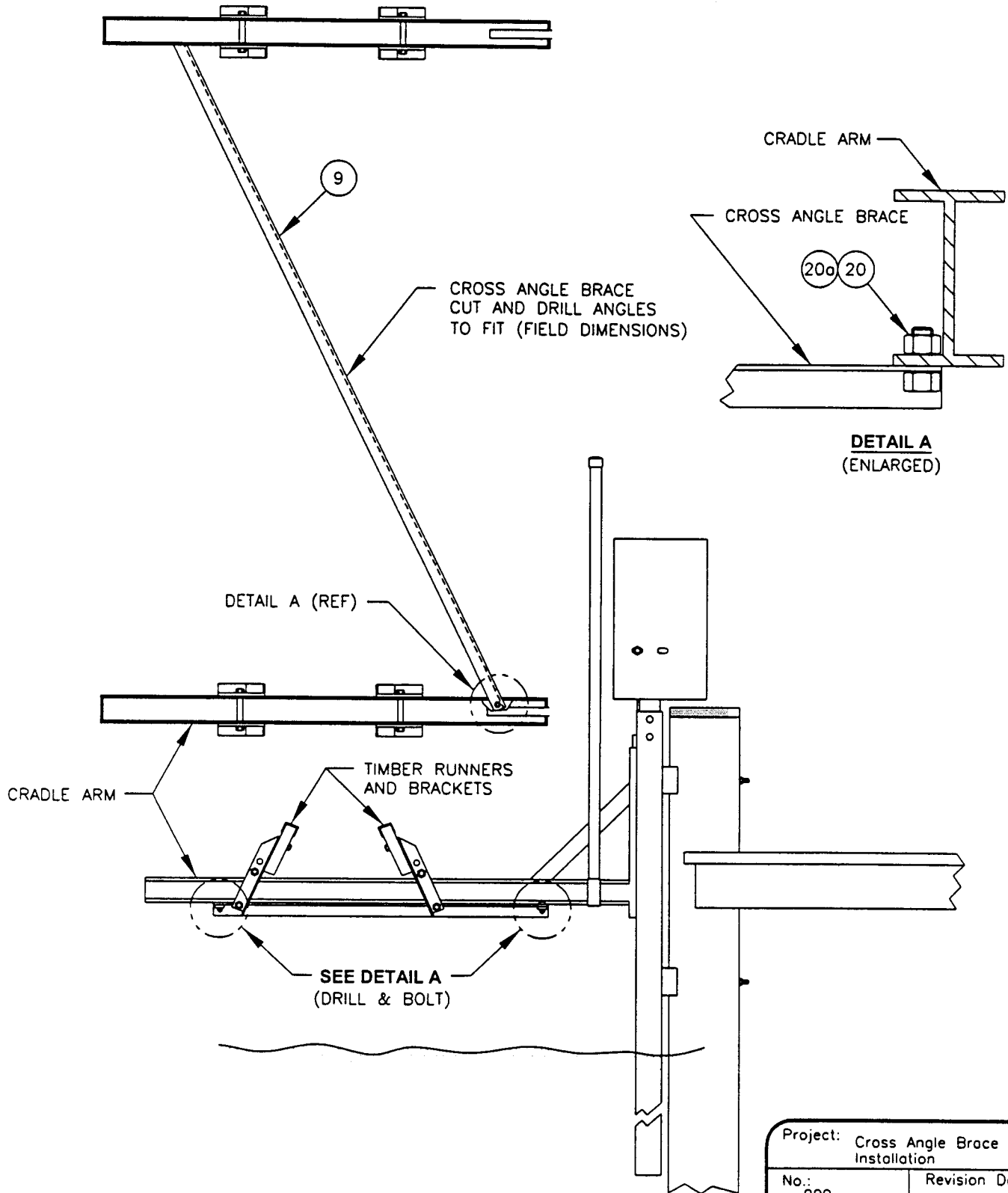

Project: Cross Angle Brace Installation		
No.: 009	Revision Date:	
Scale: None	Date: 06-26-00	Sheet: 1 of 1

GENERAL NOTE:

1. FOR LIST OF MATERIALS RELATED TO PART NUMBERS, SEE PARTS LIST.

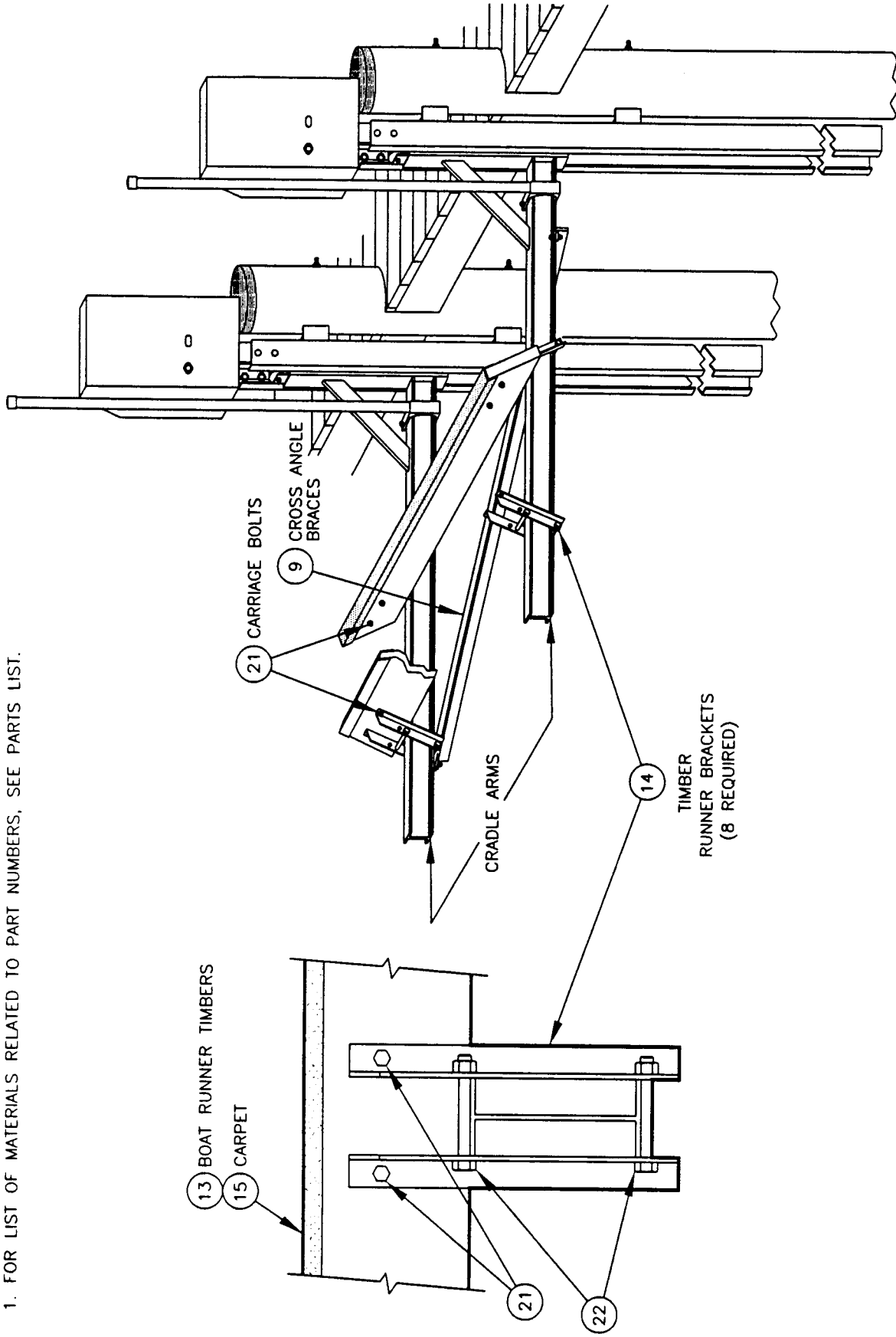

Project: Chock Rails Assembly Detail	
No.: 010	Revision Date:
Scale: None	Date: 07-16-00
Sheet: 1 of 1	



**GENERAL NOTES:**

1. FOR OPTIMUM PERFORMANCE, EQUAL WEIGHT DISTRIBUTION IS REQUIRED OVER BOTH CRADLE ARMS.
2. TO OBTAIN EQUAL WEIGHT DISTRIBUTION:
  - A. USE BALANCE POINT OF BOAT.
  - B. DO NOT USE CENTER OF BOAT LENGTH.
3. POSITION THE BOAT IN THE LIFT AS CLOSE TO THE TRACK AS POSSIBLE.

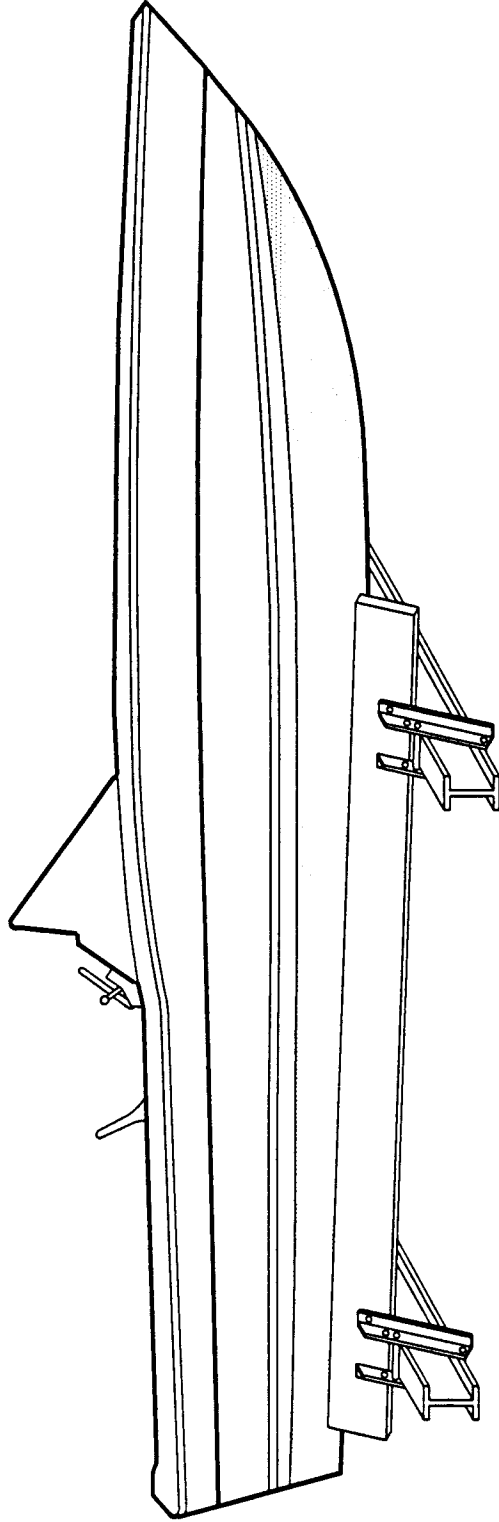

Project: Instructions For			
Weight Distribution			
No.:	011	Revision	Date:
Scale:	None	Date:	06-12-00
Sheet:			1 of 1