

# ***MAGNUM***

## **6000 lb.**

**With Strap Bearings**

# **Boat House**

## **INSTALLATION INSTRUCTIONS**

**Boat Lifts Unlimited  
Odenton, Maryland  
410-674-3100**

**Prior to installation:**

- a). To insure that the lift will operate properly, Adequate electricity should be available. Electricity will also be needed to install the lift.
- b). If available ceiling joists are to be used, insure that they are not cracked or show any signs of decay.
- c). We recommend that the ceiling joist be doubled up 2 x 10 timbers.
- d). Obtain any required local permits.

**DO NOT USE ANY POWER TOOL WHILE STANDING IN THE WATER. IF ELECTRICITY MUST BE USED NEAR THE WATER, INSURE THAT THE CIRCUIT IS PROTECTED BY A GROUND FAULT INTERRUPTER.**

**"BOATHOUSE" MODEL LIFT: 6,000 LB  
PARTS LIST**

<b>NO.</b>	<b>ITEM DESCRIPTION</b>	<b>QTY</b>
1	3/4 HP MOTOR WITH LONG CORD 15' AND BOXED SWITCH	1
2	GEAR PLATE	1
3	HINGED COVER	1
4	OVERHEAD MOTOR ANCHOR BRACKET	1
5	BEARING PIPE CARRIER	2
6	BEARING PIPE CARRIER BRACKETS	4
8	SPACER SLEEVE	1
9	10" PULLEY	1
10	4L360 BELT	1
11	1/2" BORE PLAIN SHEAVES	8
12	7/16" SHACKLES	4
13	SNATCH BLOCKS	4
14	DEAD END BRACKETS	8
15	1/4" x 40' CABLES WITH NICO AND THIMBLE	4
16	6" CRADLE BEAMS (CRADLE LIFT ONLY)	2
17	ROLLS 14' CARPET (CRADLE LIFT ONLY)	2
35	TIMBER RUNNER BRACKET	8
18	3/8" x 2 1/2" GALVANIZED CARRAIGE BOLTS (CRADLE LIFT ONLY)	8
19	3/8" GALVANIZED NUTS (CRADLE LIFT ONLY)	8
20	14' WEIGHTED SLINGS (SLING LIFT ONLY-NOT SHOWN)	2
<b>HARDWARE</b>		
21	1/2" x 1" GALVANIZED CARRAIGE BOLTS	14
22	1/2" x 1 1/2" GALVANIZED BOLTS	2
23	1/2" x 2" GALVANIZED BOLTS	2
24	1/2" GALVANIZED NUTS	28
25	1/2" GALVANIZED LOCK WASHERS	2
26	1/2" GALVANIZED FLAT WASHERS	10
27	3/16" WIRE CLIPS	4
28	5/8" x 3" GALVANIZED BOLTS	4
29	5/8" x 6" GALVANIZED BOLTS	16
30	5/8" GALVANIZED NUTS	20
31	STAINLESS STEEL HARDWARE COVERPAK	1
32	5/8" x 3" STAINLESS STEEL BOLTS	8
33	5/8" STAINLESS STEEL LOCK NUTS	8
34	5/8" GALVANIZED WASHERS	18
35	5/8" x 1-1/2" GALVANIZED HEX BOLTS	4
36	5/8" GALVANIZED LOCK WASHERS	4

GENERAL NOTES:

**⚠ IMPORTANT**—JOIST SHOULD BE ADEQUATE TO SUPPORT THE LOAD, WE RECOMMEND 2 x 10' DIMENSIONAL LUMBER. DEAD END BRACKETS SHOULD BE SECURELY ATTACHED TO THE BOATHOUSE FRAMING.

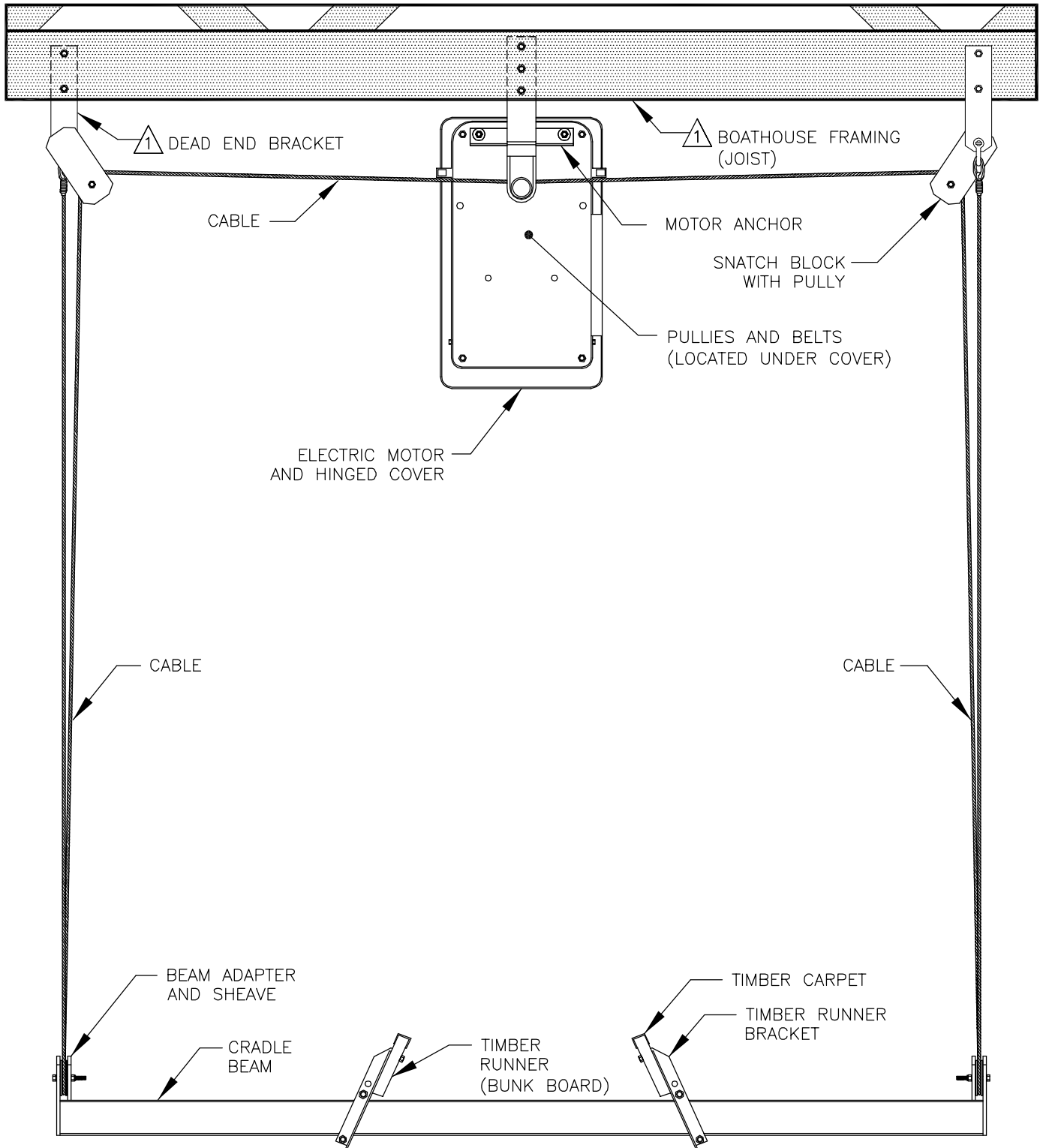

**MODEL 6,000 LB LIFT**

Project: "Boat House" Part Names (Model 6,000)		
No.: 001	Revision Date: 06-15-12	
Scale: None	Date: 06-27-01	Sheet: 1 of 1

**GENERAL NOTES:**

1. FOR LIST OF MATERIALS RELATED TO PART NUMBERS, SEE PARTS LIST.

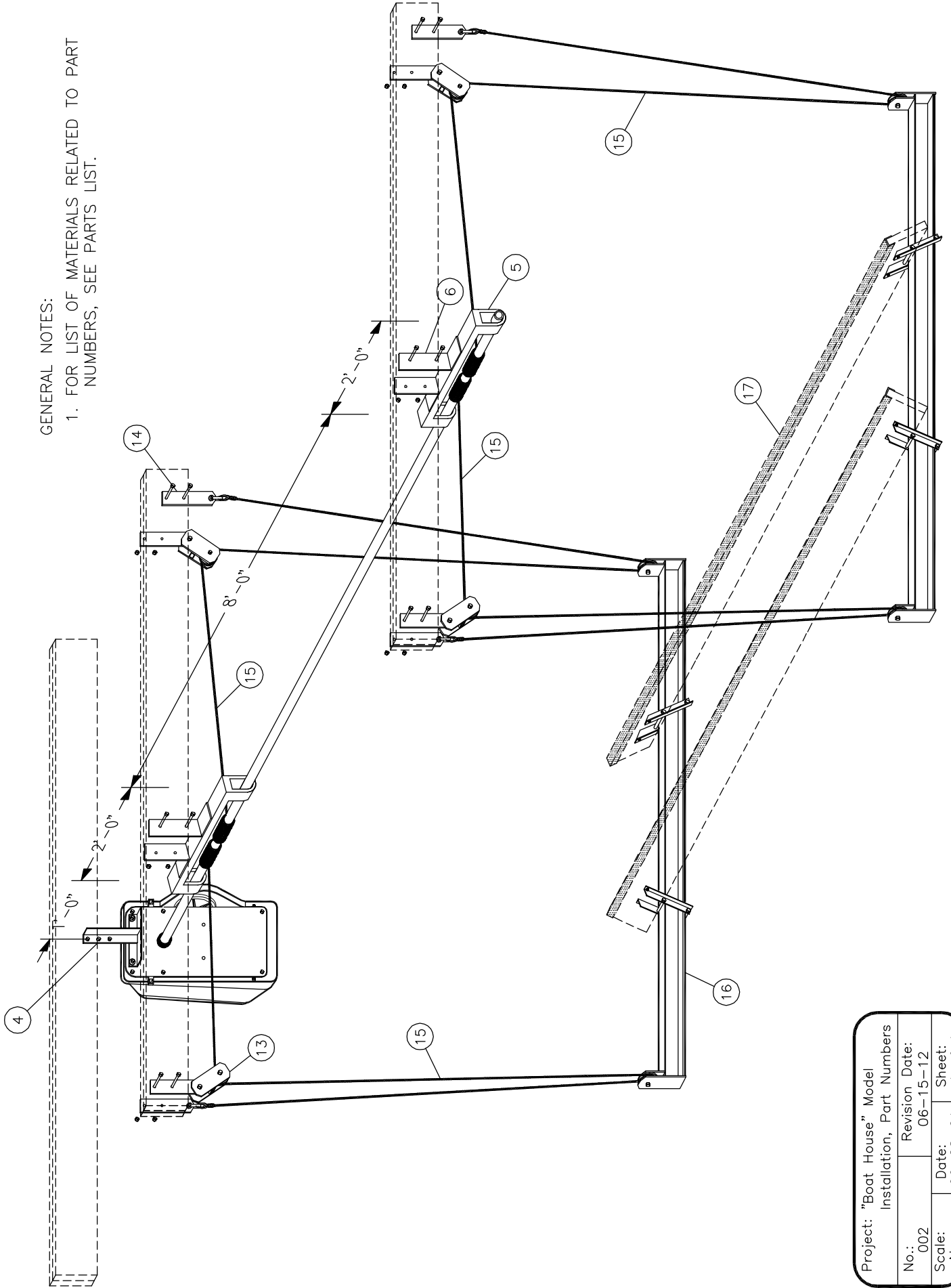

Project: "Boat House" Model			
Installation, Part Numbers			
No.:	002	Revision Date:	06-15-12
Scale:	None	Date:	06-28-01
		Sheet:	1 of 1

**BOAT LIFTS UNLIMITED, INC.**

**GENERAL NOTES:**

1. \* CAUTION: INSTALL ONLY THE HARDENED BOLT SUPPLIED WITH THE GEAR ASSEMBLY.
3. FOR LIST OF MATERIALS RELATED TO PART NUMBERS, SEE PARTS LIST.

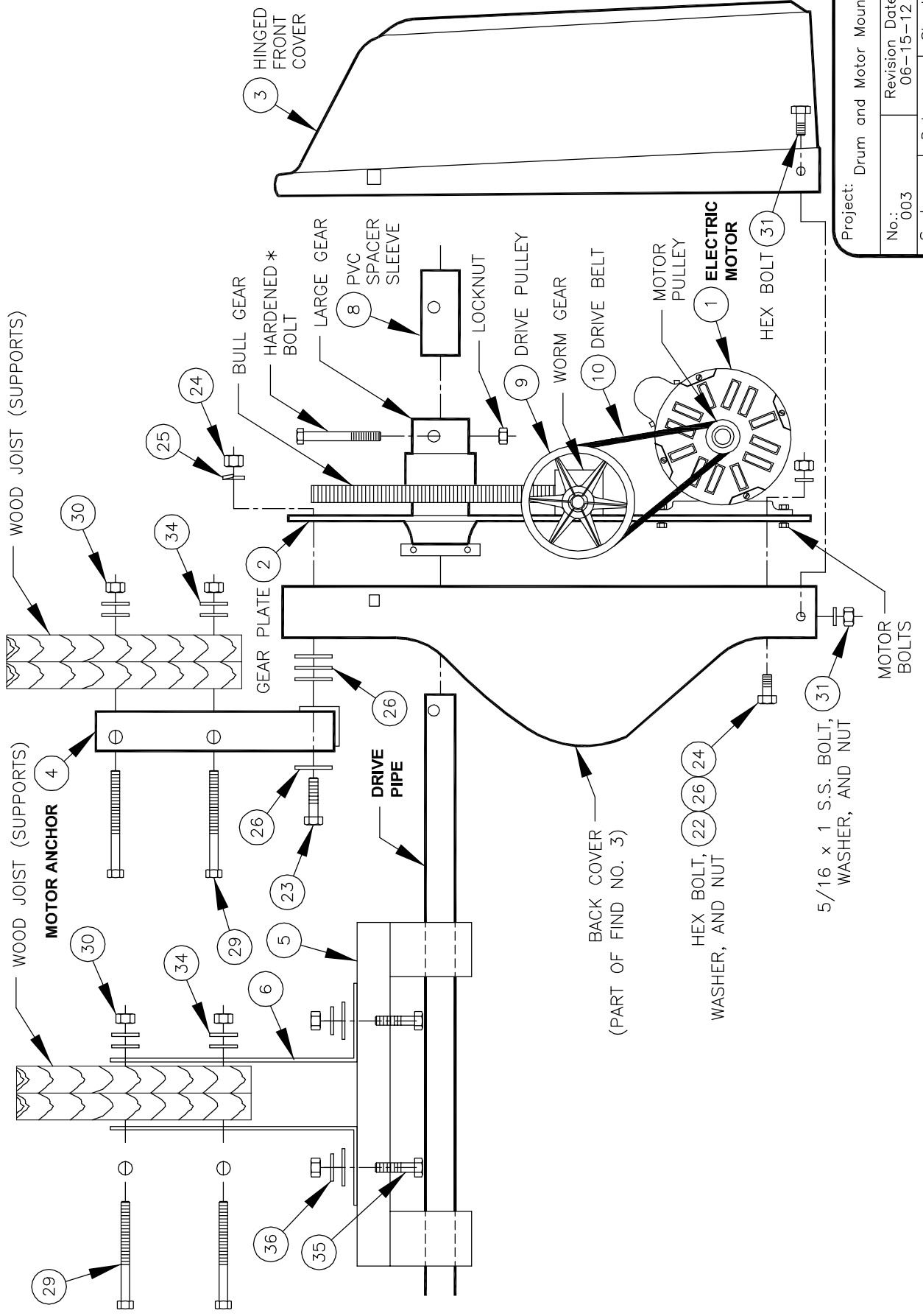

Project: Drum and Motor Mount	
No.: 003	Revision Date: 06-15-12
Scale: None	Date: 06-04-12
Sheet: 1	of 1

**GENERAL NOTES:**

1. SEE DRAWING NO. 003 (DRUM AND MOTER MOUNT) FOR A SIDE VIEW OF MOTOR AND MOTOR HOUSING.

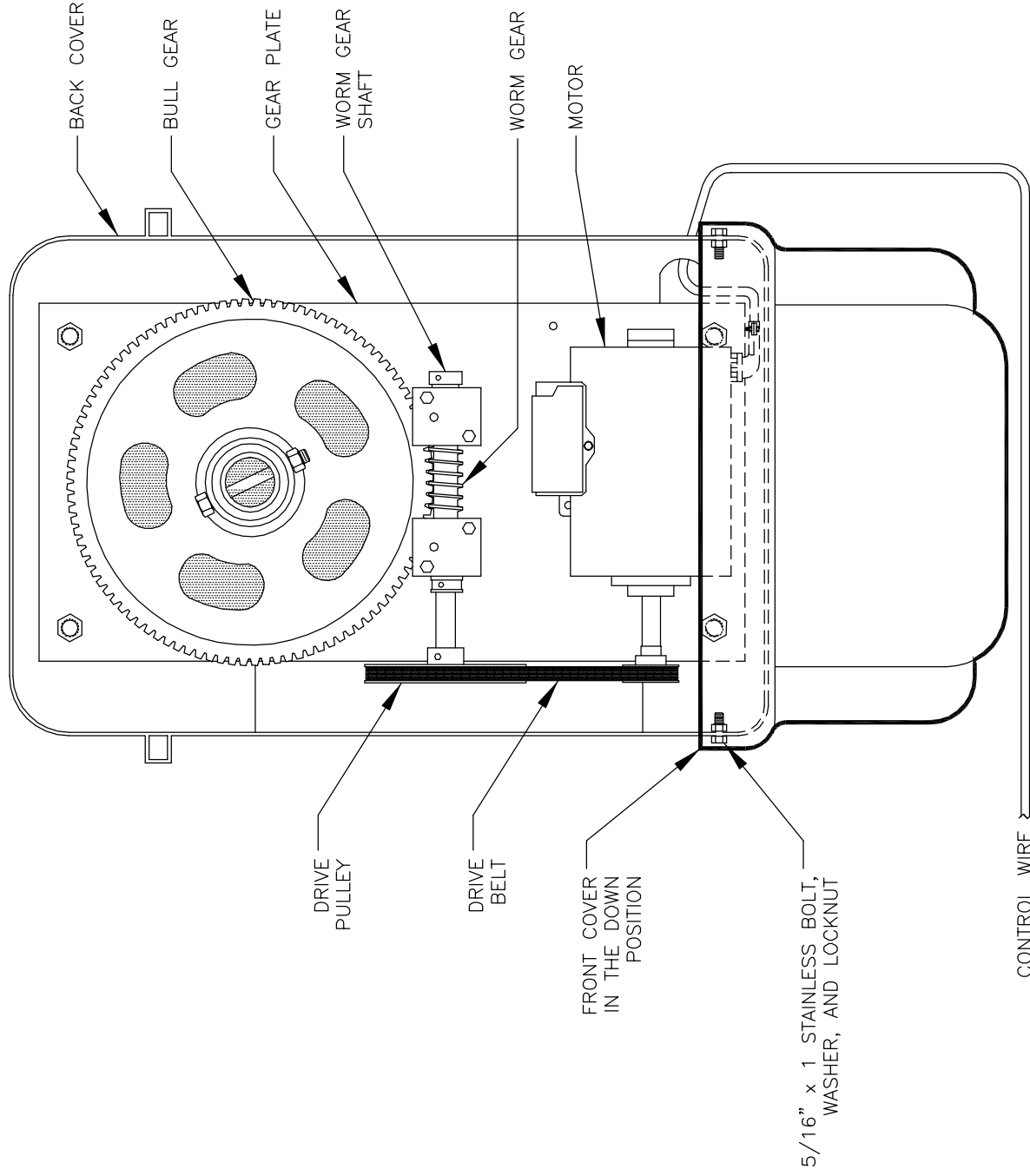

Project: Motor and Motor Housing			
No.: 004	Revision		Date:
Scale: None	Date: 06-04-12	Sheet: 1 of 1	

**MOTOR HOUSING - FRONT VIEW**

(COVER DOWN)

CONTROL WIRE  
TO REMOTE CONTROL

GENERAL NOTES:

- 1. FOR A DETAIL DRAWING OF VIEW CALLED OUT, GO TO SPECIFIED DRAWING.

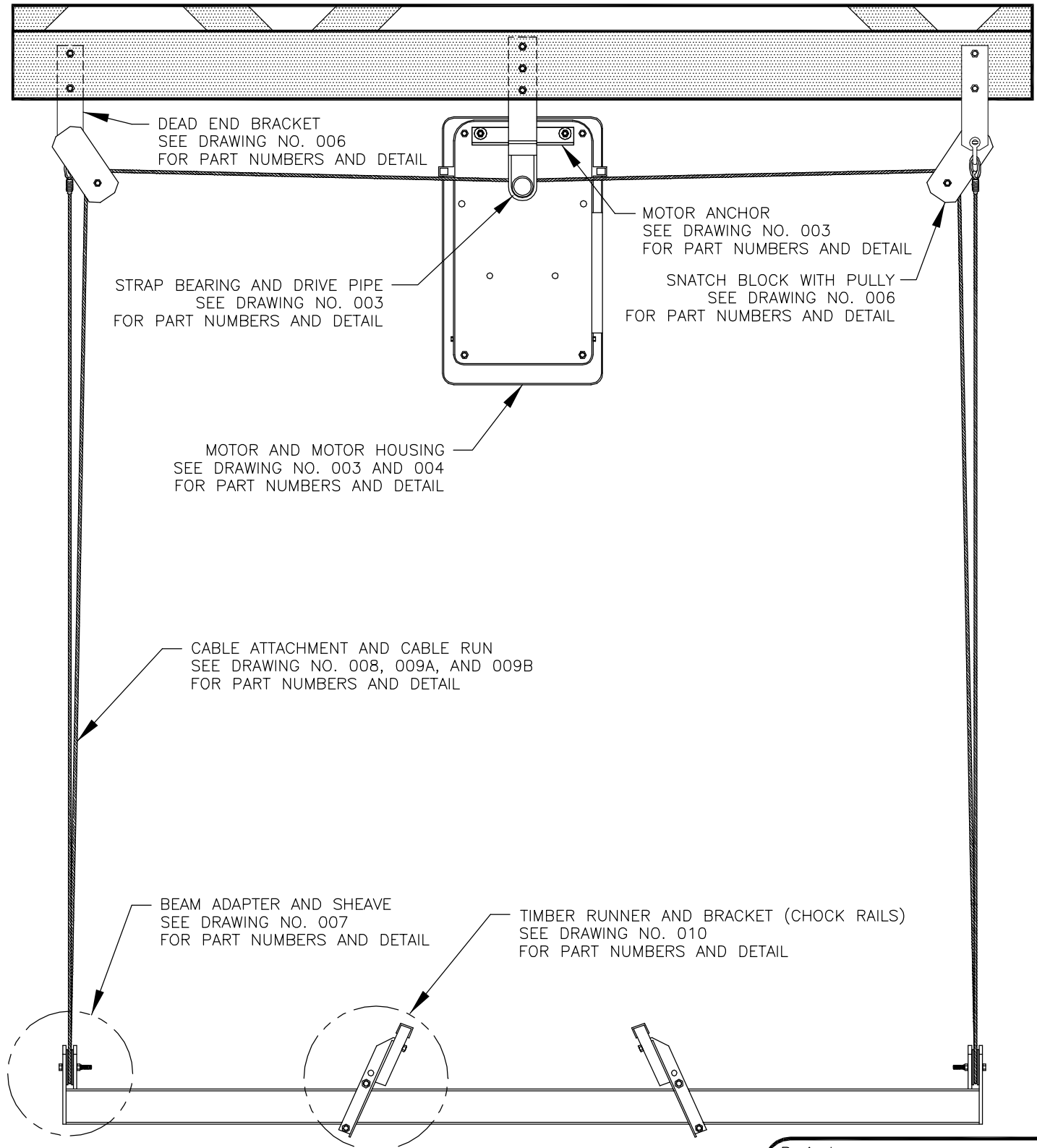

Project: Key To Detail Drawings		
No.: 005	Revision Date:	
Scale: None	Date: 06-04-12	Sheet: 1 of 1

**GENERAL NOTES:**

1. FOR LIST OF MATERIALS RELATED TO PART NUMBERS, SEE PARTS LIST.

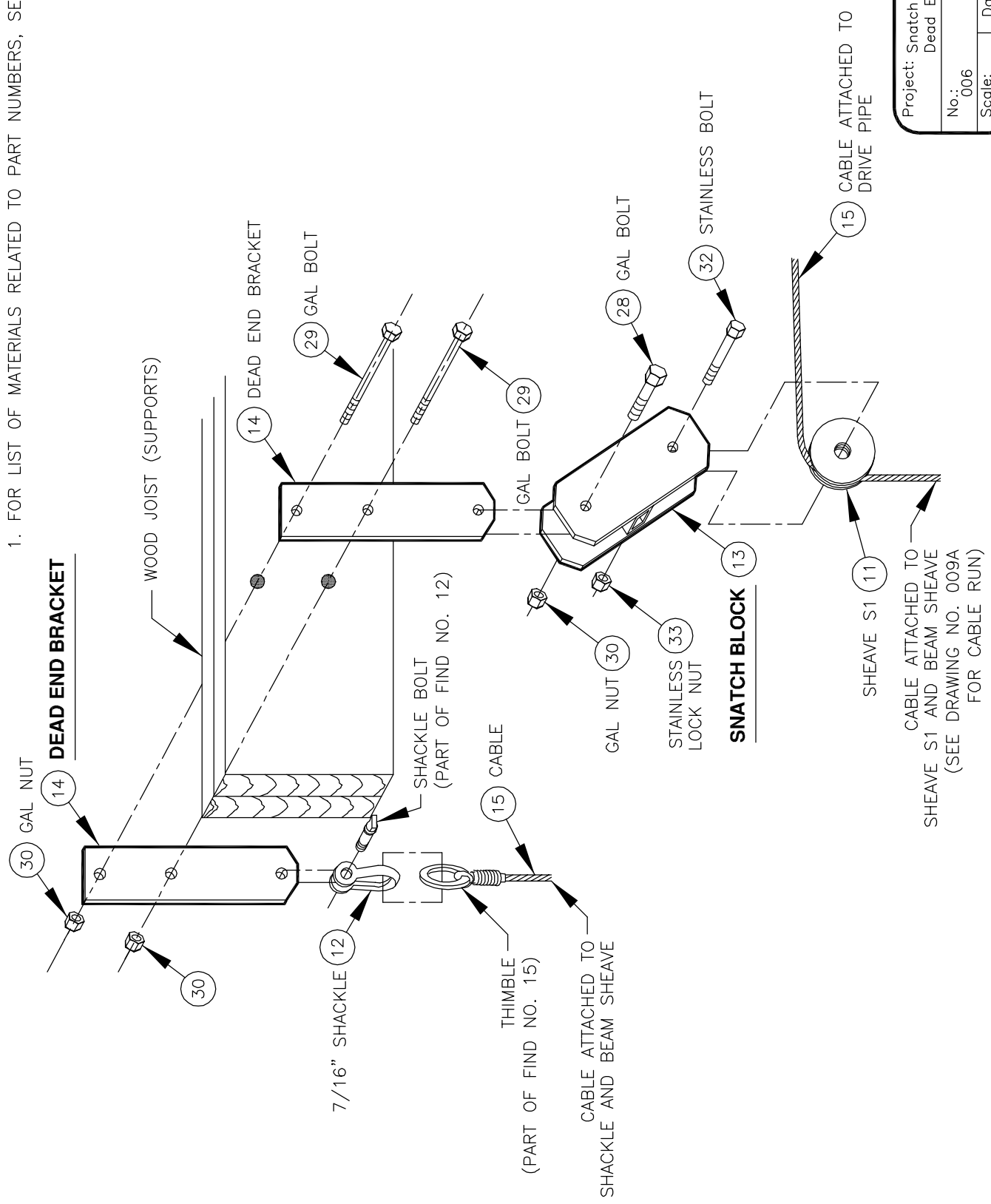

Project: Snatch Block and Dead End Bracket Detail			
No.:	006	Revision Date:	
Scale:	None	Date:	06-04-12
		Sheet:	1 of 1

SHEAVE S1 (11)  
 CABLE ATTACHED TO  
 SHEAVE S1 AND BEAM SHEAVE  
 (SEE DRAWING NO. 009A  
 FOR CABLE RUN)



GENERAL NOTES:

- 1. FOR LIST OF MATERIALS RELATED TO PART NUMBERS, SEE PARTS LIST.

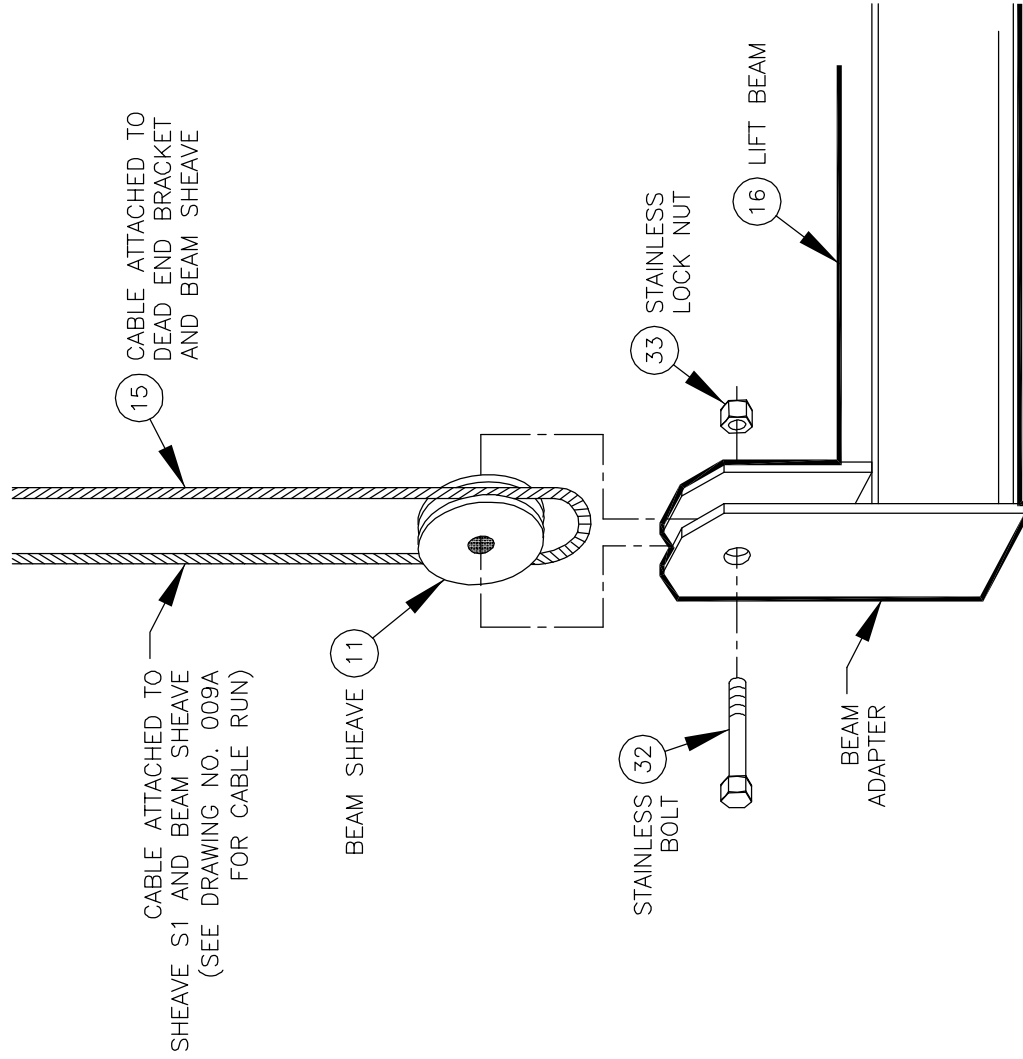

**MODEL 6,000**

Project: Beam Adapter Detail			
No.:	007	Revision	Date:
Scale:	None	Date:	06-04-12
		Sheet:	1 of 1

**GENERAL NOTES:**

1. FOR LIST OF MATERIALS RELATED TO PART NUMBERS, SEE PARTS LIST.

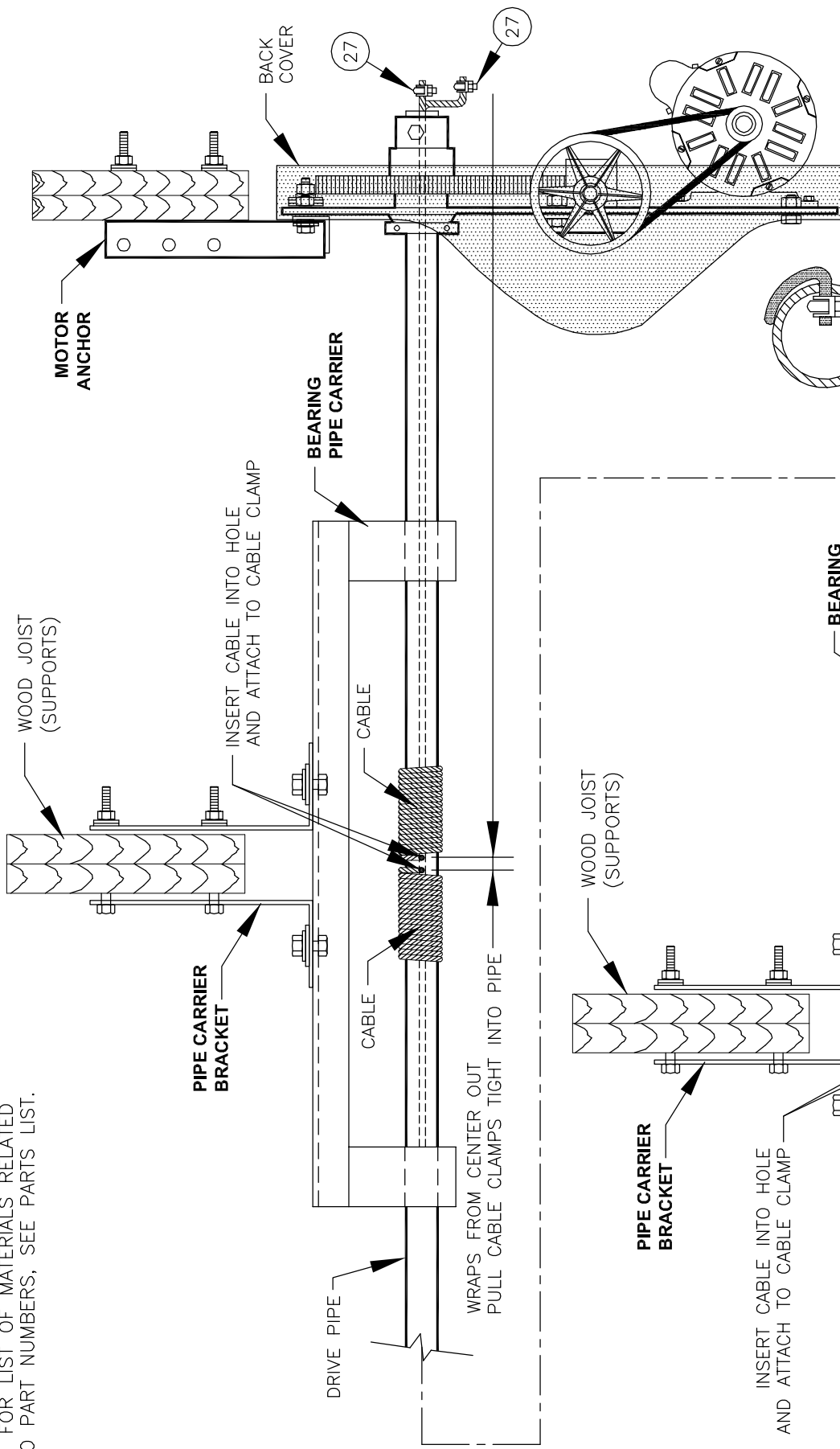

**SECTION VIEW**

CABLE CLAMP IS PULLED TIGHT INTO DRIVE PIPE

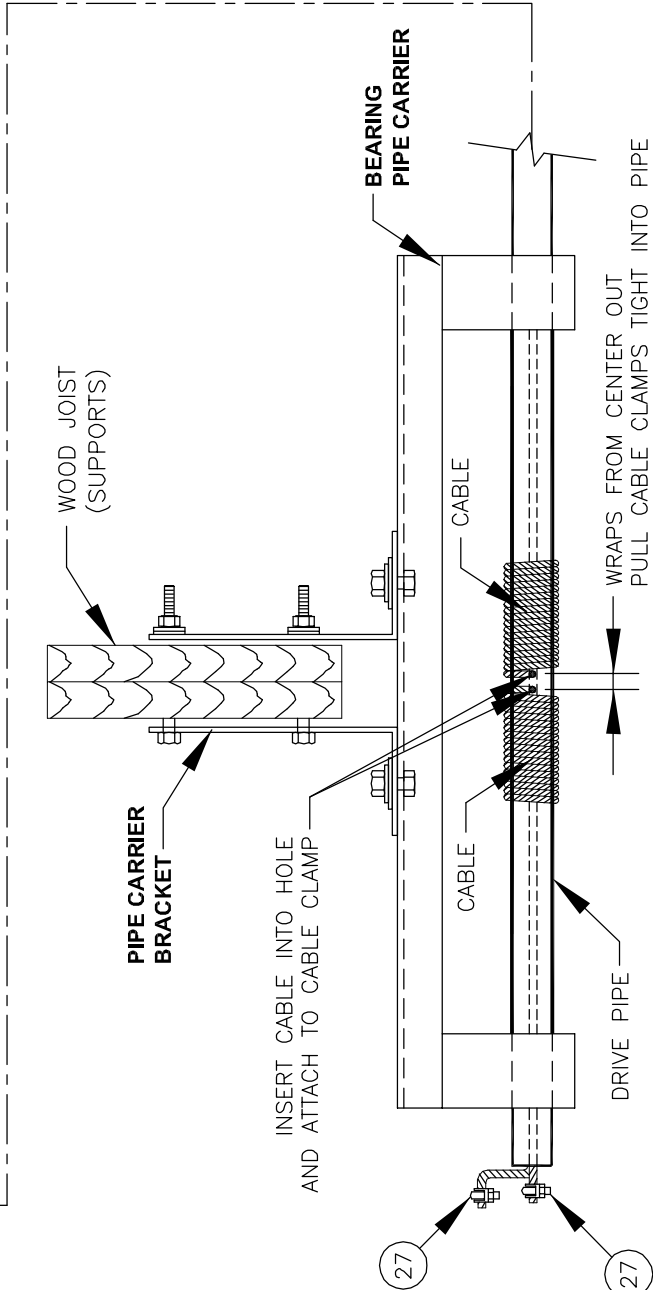

**CABLE ATTACHMENT**

Project: Cable Connections Assembly Detail and Cable Attachment

No.: 008

Revision Date: 06-15-12

Scale: None

Date: 06-04-12

Sheet: 1 of 1

**GENERAL NOTES:**

1. ENOUGH CABLE IS SUPPLIED WITH THE LIFT TO LOWER THE MAIN BEAM 20' BELOW THE SHEAVE S1 BOLT. IF A GREATER AMOUNT OF DROP IS REQUIRED, CALL YOUR LIFT SUPPLIER TO ACQUIRE LONGER CABLES.

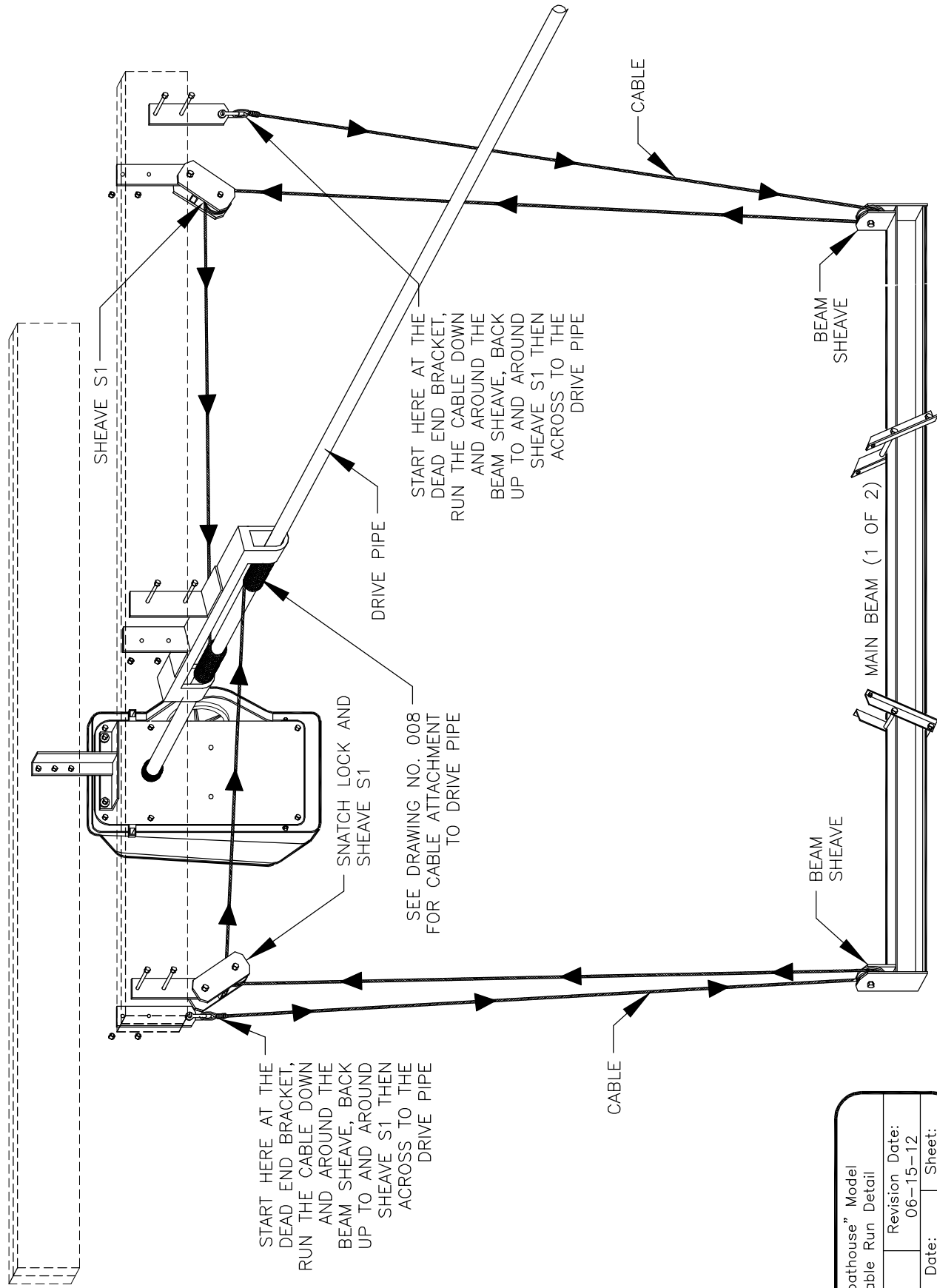

START HERE AT THE DEAD END BRACKET, RUN THE CABLE DOWN AND AROUND THE BEAM SHEAVE, BACK UP TO AND AROUND SHEAVE S1 THEN ACROSS TO THE DRIVE PIPE

SEE DRAWING NO. 008 FOR CABLE ATTACHMENT TO DRIVE PIPE

START HERE AT THE DEAD END BRACKET, RUN THE CABLE DOWN AND AROUND THE BEAM SHEAVE, BACK UP TO AND AROUND SHEAVE S1 THEN ACROSS TO THE DRIVE PIPE

Project: "Boathouse" Model Cable Run Detail			
No.:	009A	Revision Date:	06-15-12
Scale:	None	Date:	07-19-01
		Sheet:	1 of 2

**GENERAL NOTES:**

1. ENOUGH CABLE IS SUPPLIED WITH THE LIFT TO LOWER THE MAIN BEAM 20' BELOW THE SHEAVE S1 BOLT. IF A GREATER AMOUNT OF DROP IS REQUIRED, CALL YOUR LIFT SUPPLIER TO ACQUIRE LONGER CABLES.

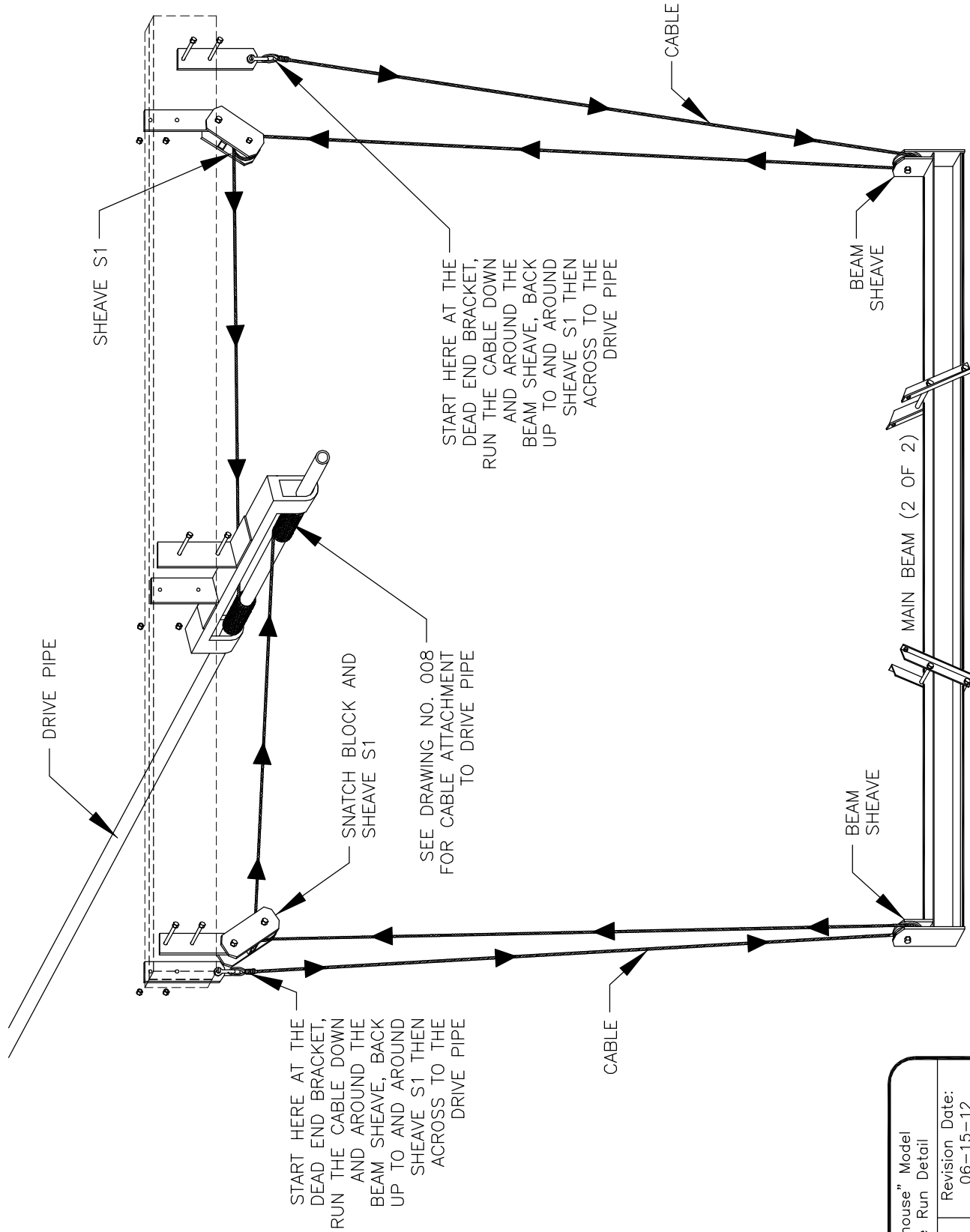

Project: "Boathouse" Model Cable Run Detail	
No.: 009B	Revision Date: 06-15-12
Scale: None	Date: 07-19-01
	Sheet: 2 of 2

**BOAT LIFTS UNLIMITED, INC.**

GENERAL NOTES:

1. BUNK BOARDS, IF NOT SUPPLIED, SHOULD BE 2" x 8" OR 2" x 10" DIMENSIONAL LUMBER.
2. FOR LIST OF MATERIALS RELATED TO PART NUMBERS, SEE PARTS LIST.

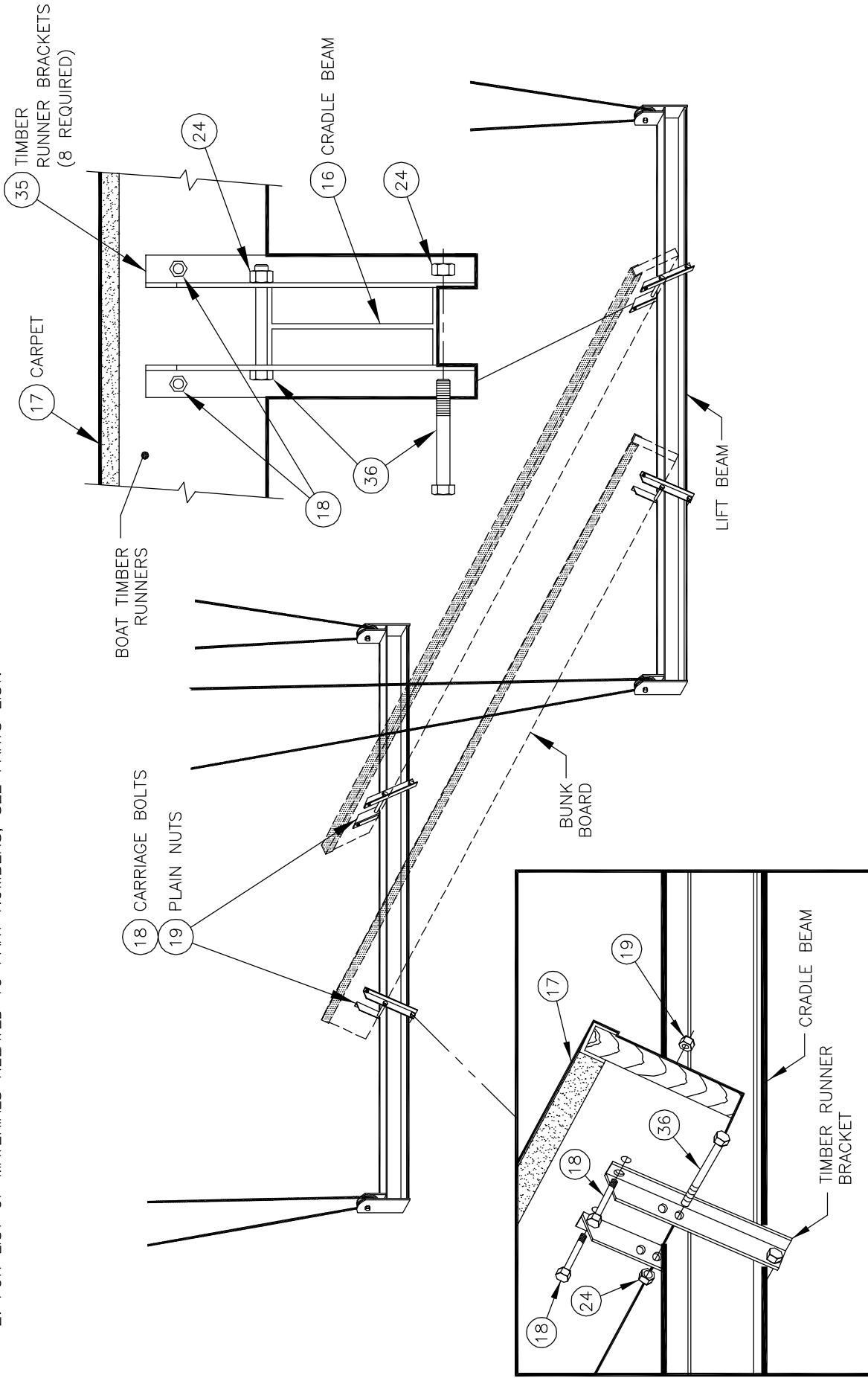

Project: Chock Rails Assembly Detail	
No.: 010	Revision Date: 06-04-12
Scale: None	Date: 07-19-01 Sheet: 1 of 1

GENERAL NOTES:

- 1. FOR OPTIMUM PERFORMANCE, EQUAL WEIGHT DISTRIBUTION IS REQUIRED OVER BOTH CRADLE ARMS.
- 2. TO OBTAIN EQUAL WEIGHT DISTRIBUTION:
  - A. USE BALANCE POINT OF BOAT.
  - B. DO NOT USE CENTER OF BOAT LENGTH.

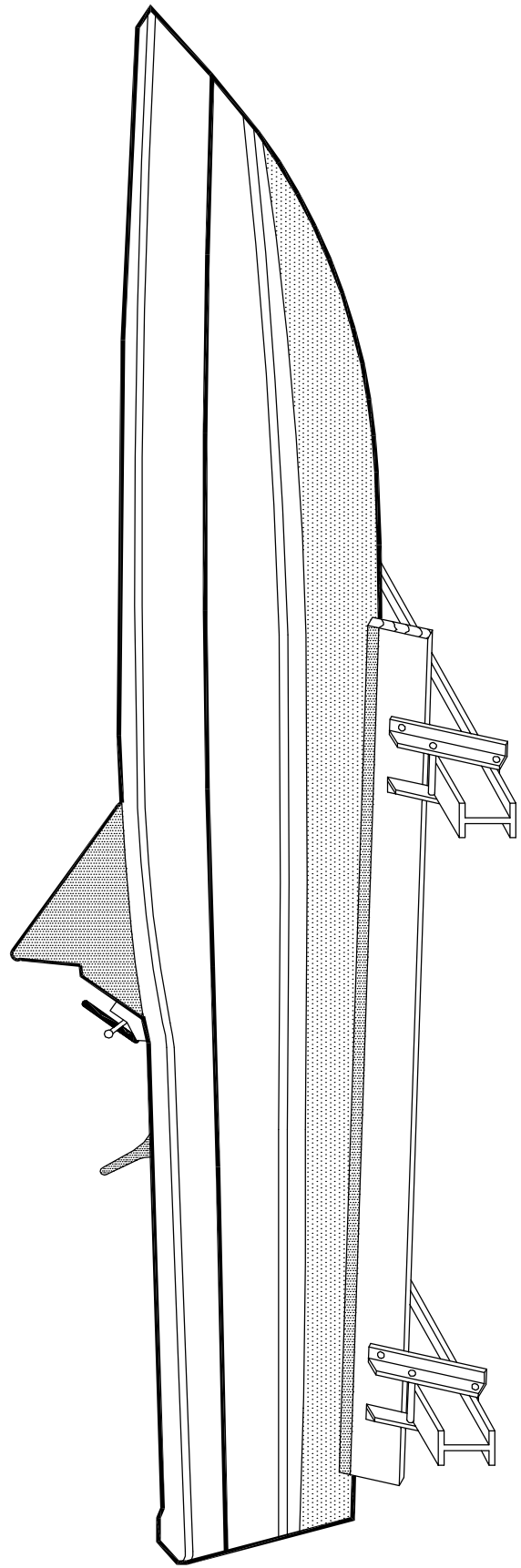

**SIDE VIEW OF BOAT**

Project: Instructions For	
Weight Distribution	
No.: 011	Revision Date: 06-04-12
Scale: None	Date: 07-19-01
	Sheet: 1 of 1