



MINI MAG

MFD BY BOAT LIFTS UNLIMITED

MINI MAG BOLTED ARM OPTION

Installation Instructions

The Bolted Arm Option is an alternative to the traditional welded arm that is easier to handle and install without a compromise in strength. The Bolted Arm Option includes the following..

- I. (1) 1500lb Bolted Arm Backbone
- II. (1) 1500lb Bolted Arm Shoulder
- III. (2) 1500lb Arm
- IV. (12) 5/8 x 1 ½ Galv Hex Bolt
- V. (12) 5/8 Galv Nut

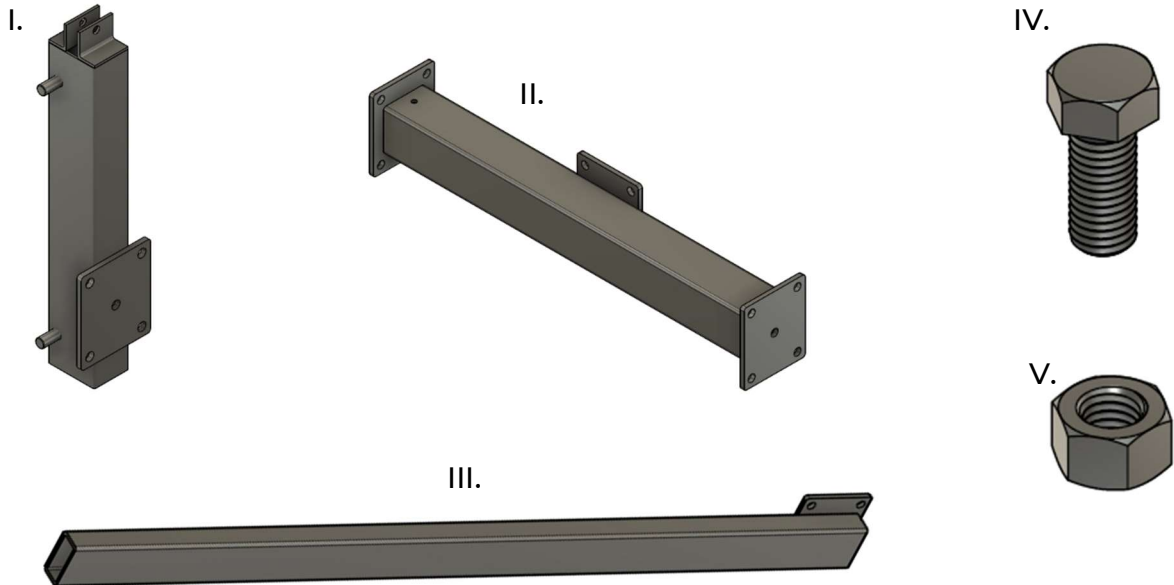

*Images are not to scale

****Once you have the track installed and secured,
you are ready to assemble the bolted arm. ****

- 1) Before putting the backbone into the track, you must bolt the backbone and shoulder together.

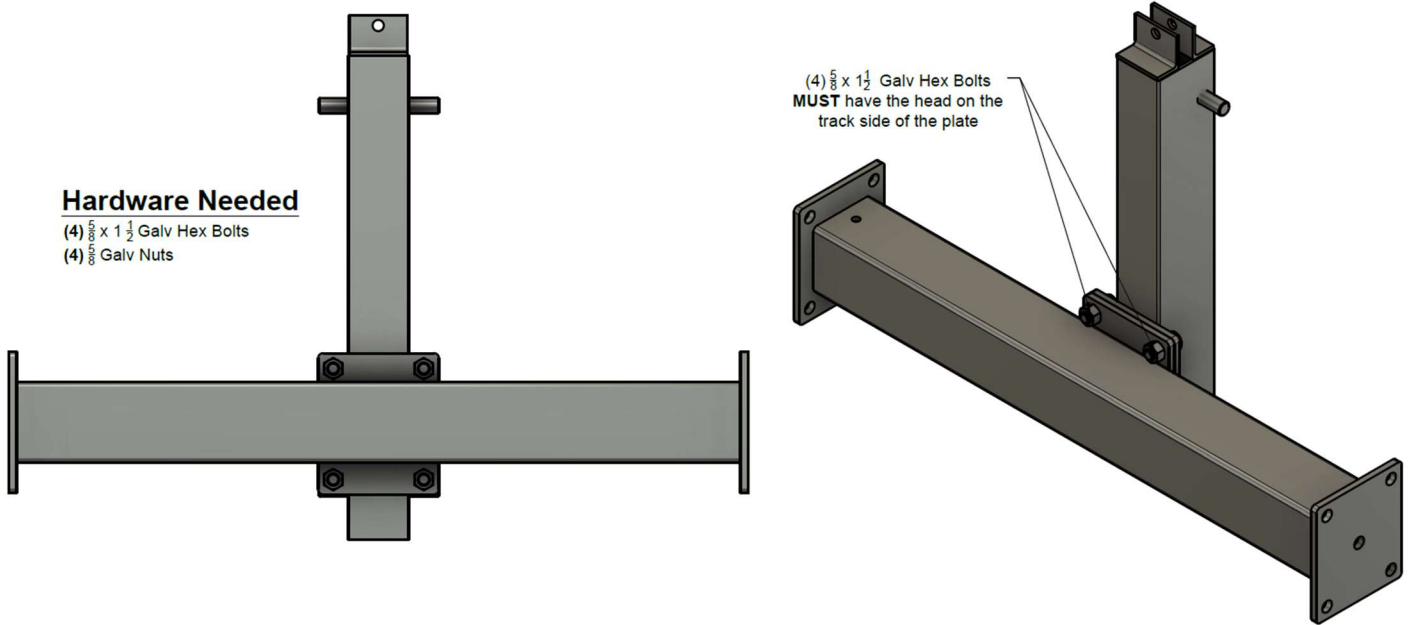

- 2) Insert the assembled backbone and shoulder into the track from the top so that the tabs for the sheave are facing up.

- 3) Finally, bolt the arms to the shoulder.

